

Ripmax **Futaba**®

INSTRUCTION MANUAL



F-14/F-14 Navy

P-CBF14N / P-CBF14NB

 **SAFETY WARNINGS, PLEASE READ.**

Before operating your model for the first time, you must read these instructions very carefully, especially the safety warnings. If this is your first time operating a remote controlled car, boat, plane or helicopter we recommended that you seek advice from an experienced pilot.

This transmitter is designed for the use of remote controlled cars, boats, planes and helicopters only. Ripmax is not liable for any other application.

SAFETY WARNINGS

Remote controlled models are not conventional toys and are only to be operated under adult supervision for users below 14 years of age. The assembly and use requires technical understanding, care and a safety conscious operation. Faulty assembly or careless operation can cause serious damage to persons and property.

The manufacturer and retailer of the models have no influence over the correct assembly and use of the product and therefore are excluded from any liability claims. Therefore it is important to read the safety instructions very carefully.

Technical defects of a mechanical or electric nature can result in the sudden starting of the motor and loose parts can be catapulted at high speeds into the surrounding area. The same can be caused by a switched on receiver without the transmitter being turned on.

This can cause physical harm. Propellers, helicopter blades and other rotating parts powered by a motor are always a potential source of danger and can cause injuries. Therefore, it is essential not to touch any rotating parts. A rotating propeller can cause the loss of a finger!

Keep a safe distance from rotating parts and propellers once the electric motor is connected to the battery and also take care not to touch the rotating parts with any other parts!

Protect your transmitter from dust, dirt and humidity and do not let your transmitter be in surroundings that are too hot, too cold or vibrating. Your transmitter is designed to operate correctly within a temperate range of -15°C - $+55^{\circ}\text{C}$.

Only use recommended chargers and charge your battery only for the recommended time period. Please follow the instructions issued by the battery manufacturer. Overcharging your battery or charging it incorrectly can lead to explosion. Please ensure correct polarity.

Please avoid pressure and knocks to your transmitter and always check for damage on the housing, cables and connectors. Wet or damaged transmitters are not to be used, even after they have dried out! Please service the transmitter by your Futaba Service Centre or replace the item.

Wet conditions and damage can cause errors which in turn can cause the loss of function after short use. Only use the parts and optional accessories recommended by us and always use the original Futaba connectors.

WARNING:

Do not touch the antenna during flight as transmission is reduced significantly.

ROUTINE CHECKS BEFORE EVERY START:

- Always switch on the transmitter and then the receiver and before switching on the receiver, ensure that the throttle stick is in the neutral position.
- Always switch off the receiver first and then the transmitter.
- Always test range
- Always check all functions and check the direction of rotation and surface movements for your model.
- Check that the correct mixing functions and switches are selected.
- Is the battery charged?
- If in doubt, never start the model!

Operating your model

- Never fly above crowds and other pilots.
- Never endanger people or animals.
- Never fly in residential areas or near power lines.
- Never fly near locks or shipping traffic sites
- Never fly your model on public roads, motorways, pathways and places etc.

Do not use your transmitter in thunder storms.

During flight, never point the transmitter aerial directly at the model as transmission is greatly reduced in this position. Ideal is a sideways position towards the model.

INSURANCE

Ground operated models such as cars and boats are usually included in general public liability insurance but for flying models it is required by law to obtain separate liability insurance. If you have a liability insurance policy, please check with your insurance issuer if flying models are also covered by your policy. If in doubt, take out a separate liability insurance policy.

Liability exemptions

Ripmax cannot be held liable for any loss, damage or cost incurred by user error, faulty installation or any other connected activities as we cannot oversee and guarantee the correct assembly, usage or maintenance of the transmitter parts

1. FUTABA F-14 RADIO CONTROL SYSTEM

You are now the owner of a multi-option radio control set with extensive expansion facilities which give you the chance to create a system which meets your personal requirements exactly. The F-14 transmitter features an angled front face and includes five option wells to take your choice of extra modules.

The F-14 RC system is easy and logical to use, but never theless you will need to absorb some information in order to get the best out of the equipment, just like any other highquality radio control set. These instructions provide all you need to know to become familiar with the system's features and facilities.

Please take the time to read through these operating instructions attentively before you attempt to use the system for the first time, as this will answer all your questions. We are confident that you will enjoy using the F-14 for many years, and wish you lots of luck and pleasure in your hobby.

Set contents

The F-14 set is supplied with the following items:

- 1 F-14 or F-14 Navy transmitter
- 1 Receiver: R-168DF 40 MHz
- 1 S 148 servo
- 1 Pack servo accessories
- 1 Switch harness with charge socket
- 1 Pair of crystals

Our product range includes an extensive array of optional accessories which you can fit to produce your own personal transmitter.

Contents

	Page
1. Introduction	3
Set contents	3
2. The F-14 transmitter	3
Description of transmitter	3
Specification	3
Transmitter controls	3
Installing the battery	3
Operating times	4
Charging the batteries	4
Changing the crystals	5
Adjusting the sticks	5
Unrestricted function assignment, Servo reversing	6
3. Receiver and servos	6
Specification	6
Connecting the receiving system	6
Installing the receiving system	6
Receiver power supply	8
The system in use	8
4. Expanding the transmitter	8
Expansion facilities	8
Special accessories	9
5. Appendix	12
Administration regulations	12
Repairs, service centre addresses	12
Service centre addresses	12

2. THE F-14 TRANSMITTER

Description of transmitter

The F-14 is a 4-(8) channel frequency modulation (FM, PPM) transmitter with an angled front face, equally suitable for controlling model aircraft, boats and cars.

The following list includes the essential performance features of the F-14 transmitter.

- Modern angled-face transmitter with 4 main functions; expandable to 8 functions
- Servo reverse for all functions: servo direction can be reversed at the transmitter to simplify servo installation in models
- Unrestricted control function assignment: you can select any sequence of receiver connections.
- 3 option wells for installing switches, Multi-Prop or Multi-Switch modules
- 2 option expansion wells for installing proportional channel sliders
- transmitter LEDs display the voltage of the NiMH pack
- Precision sticks for accurate control; individually adjustable to suit your personal preference
- Central support lug: attach a neckstrap and the weight of the transmitter can be borne by your shoulders for fatigue-free use.
- Moulded-in recesses in the back of the transmitter provide an excellent grip when the transmitter is used handheld.

Specification

Functions:	8 / 4 servos
Function expansion:	8 / 4 servos
Frequency bands:	40 MHz
Channels:	22 (40 MHz)
Modulation:	FM (PPM)
Channel spacing:	10 kHz
Power supply:	9.6 V NiMH battery
Current drain:	220 mA
Dimensions:	230 x 200 x 50 mm
Weight (excl. battery):	600 g

Transmitter controls

All the transmitter's primary controls are mounted on the front panel. The charge socket is on the right-hand side of the case, the aerial compartment on the left-hand side.

The special shape of the transmitter case angles all the switches and controls towards you for easy access.

This means that everything can be operated without you having to take your eyes off the model. Fig. 1 shows the transmitter controls.

Installing the transmitter battery

Modern radio control transmitters are sophisticated electronic devices, and for this reason it is essential that they are powered by batteries of the correct type. Dry cells are not a good choice, and even individual NiMH penceils (i.e. not a soldered pack) cannot be recommended as vibration can cause intermittent contact and unreliable operation. Please note: if you connect a battery with reverse polarity the transmitter may be damaged, and we cannot accept claims under guarantee if you make this basic error.

We recommend to use transmitter batteries from our product range. These batteries are supplied as standard with a polarised connector which matches the transmitter (order no. O-8EN2000AAWF).

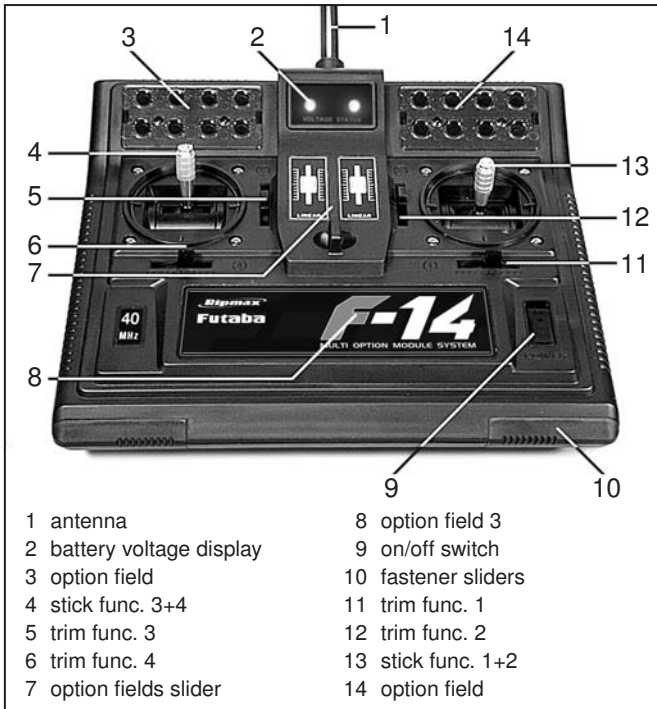

Fig. 1

To install the battery the back panel must first be removed as follows: push the two latch sliders outwards for a distance of about 2 cm as shown in Fig. 2. The back panel can now be lifted off forwards under light pressure. Check that the aerial does not fall out of its holder when you do this.

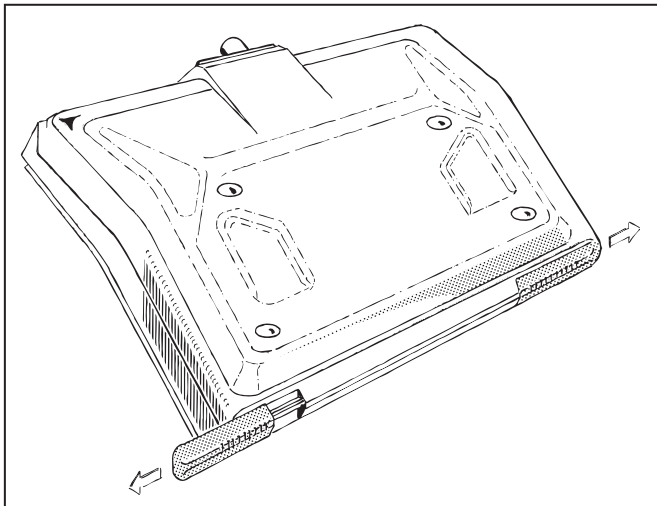
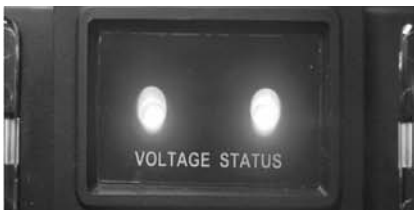

Fig. 2

F-14's voltage indicator

The LED voltage indicator shows the voltage of your transmitter battery by means of various LED sequences.



1) Two LEDs light up:
Voltage 9.2 V or more. Battery capacity between 100 and 30%.



2) One LED lights up:
Voltage 9.2 V, remaining battery capacity approx. 20%.
Note:
Battery needs to be recharged soon.



3) One LED flashes (low voltage alarm):
Voltage 9.0 V or less. Remaining battery capacity approx. 10%.
Note:
You must cease operations!

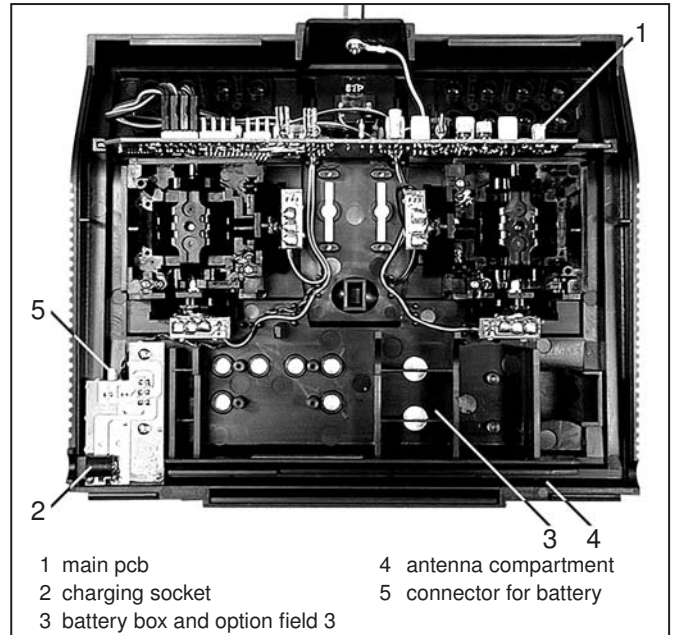

Fig. 3

Fig. 3 shows an internal view of the transmitter. Place the battery in the recess provided for it; the back panel will hold it in place securely. Deploy the cable from the battery to the circuit board as shown, and push the socket firmly onto the appropriate pins. The connector is polarised, i.e. it can only be connected the right way round.

Close the transmitter by reversing the procedure described above. Note that the transmitter back panel should first be engaged at the front, then at right and left.

Operating times

With a 1400 mAh battery the transmitter will operate for about 6 hours. If you fit a 2000 mAh battery the maximum operating time rises to about 8 hours. Please note that this does not apply to the receiver battery. The receiver battery's operating time varies greatly according to the number of servos connected to it, the freedom of movement of the control linkages, and the frequency of control commands.

For this reason it is very important to ensure that all mechanical linkages move freely, and that the servo is not mechanically obstructed or restricted at any point in its travel.

Charging the batteries

We recommend that you also use a factory-made battery pack for the receiving system. Glow motors can cause vibration in the model, with the resultant danger of loss of control due to intermittent contact, and welded or soldered packs eliminate this problem. When the receiver battery is almost discharged you will notice that the servos run markedly more slowly.

The notes above regarding the transmitter battery also apply to the receiver pack. Please note that all rechargeable batteries in the RC system should be given a slow charge at the 1/10 rate (standard charge rate, example: 500 mAh battery-charge current 50 mA) for at least 14 hours, regardless of how long you used the system last time. This compensates for the fact that NiMH batteries self-discharge when stored. On average NiMH cells discharge themselves at a rate of about 1% capacity loss per day. This means that a fully charged pack will be completely flat after 100 days even if you do not use it at all during that time.

Most battery chargers feature LEDs (light-emitting diodes) to indicate that charging is in process, i.e. the batteries are on charge when the LEDs glow. We recommend a battery charger from our product range.

The illustrations of the transmitter show the position of the battery charge socket. Fig. 4 shows the schematic arrangement of a typical battery charging circuit.

The transmitter and receiving system must always be left switched off when you are charging the batteries. If you prefer to rapid-charge the transmitter battery the charge current must not exceed 1 A, as the transmitter could be damaged at higher currents. The transmitter features an integral protective diode which prevents damage if the charge lead is connected with reverse polarity.



Fig. 4

The first step is to connect the banana plugs attached to the charge leads to the battery charger, then connect the charge leads to the charge sockets on the transmitter and receiver switch harness. The receiver battery can safely be left in the model for charging. Using a switch harness with integral charge socket means that you do not have to disconnect the receiver battery from the switch harness for charging.

After a long period of storage, after initial purchase or after the Winter break, the batteries should be charged and discharged several times before you use the system to control a model. This cycling process „balances“ the packs and restores their full capacity and operating time.

Faulty or exhausted batteries must not just be thrown in the household rubbish as they constitute toxic waste and are potentially harmful to the environment. Always take such packs to the appropriate collection point for toxic materials.

NC batteries can be recycled, and this restores the poisonous heavy metals to the production cycle and prevents them entering the environmental chain. Please do your bit to protect and preserve the environment!

Changing crystals

Within their fixed frequency bands the transmitter and receiver can be operated on different spot frequencies by changing the crystals. Note that the crystal in the transmitter and the receiver must be changed together, as they must be a matching pair.

The frequency band of the transmitter and the receiver must be the same, and in each case a pair of matched crystals designed for that frequency band must be used. Always use original crystals from the Futaba range exclusively.

The position of the transmitter crystal socket is shown in For the R168DF receiver, dual conversion crystals are needed!

Fig. 5: it is located on the main circuit board. To change crystals you must first open the case as described earlier. Check that the transmitter is switched off before you do this.

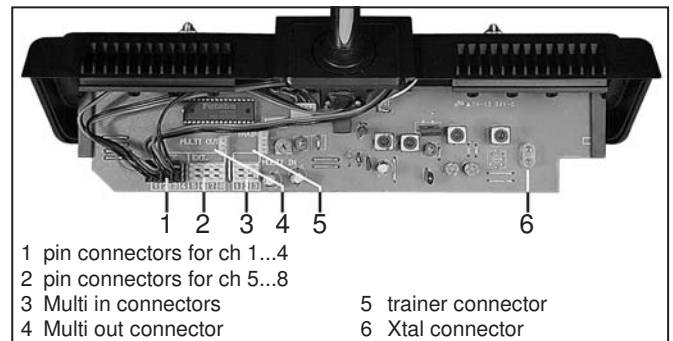

Fig. 5

Adjusting the sticks

The length of the sticks can be adjusted to suit your personal preference, and the procedure is shown in schematic form in Fig. 6. Loosen parts A and B, set the stick end to the desired length and lock part A against part B again. If you wish to use the transmitter as a hand-held unit we recommend the shorter stick ends. If you intend to use the transmitter in a tray the longer stick ends are usually a better choice.

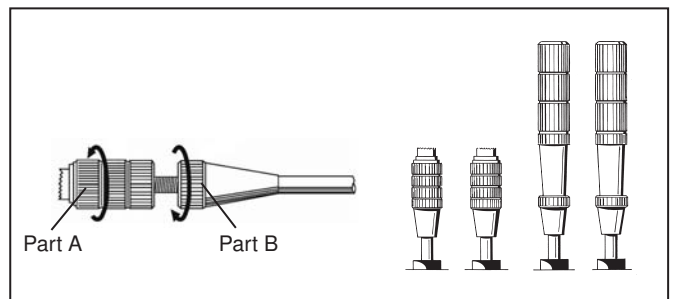

Fig. 6

The centring spring tension of both stick units is infinitely variable to suit your personal taste. To make adjustments you must remove the transmitter back panel as described earlier. The next step is to disconnect the battery from the circuit board - this is important.

The spring tension can now be adjusted for each function separately using a small screwdriver. The position of the adjustor screws can be seen in Fig. 7. Rotating the screw clockwise increases the spring tension (the stick feels „harder“). Turning the screw anti-clockwise reduces the tension, and the stick feels „softer“.

The transmitter is supplied as standard with all four stick functions set up with self-neutralising action. However, one of the two vertical planes of movement is usually converted to ratchet operation to allow for functions which do not require self-neutralisation. With ratchet operation the stick affected stays

where you put it instead of returning to centre automatically. This type of function is required, for example, to control the throttle of a glow motor.

The set is supplied with a ratchet spring and retaining screw for this purpose. You can place the throttle function on the right or left stick to suit your preference.

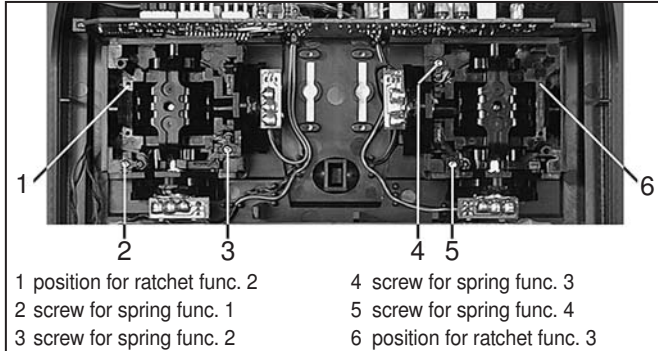

Fig. 7

The position of the throttle ratchet on each stick is shown in Fig. 7.

The first step is to screw the throttle ratchet spring in place as shown, and then to disengage the corresponding centring spring. This is done by rotating the screw fully to the left; the spring can then be lifted out with a pair of tweezers. The last step is to remove the neutralising arm. The vertical plane of this stick unit is now set to „non self-neutralising“ action.

Unrestricted function assignment, servo reversing

As standard the transmitter is supplied with all the internal cables connected. In its default state the order, or assignment, of the stick functions (number adjacent to the stick unit trims) corresponds to the numbers printed next to the output sockets on the receiver. If the stick unit connectors are left connected to the main circuit board in the standard arrangement, the servos should be connected to the correspondingly numbered receiver output sockets.

The table below shows a typical function assignment for a model aircraft:

Stick No.	Control function	Receiver output
No. 1	Aileron	1
No. 2	Throttle	2
No. 3	Elevator	3
No. 4	Rudder	4

However, if you are used to a different arrangement of the transmitter controls it is possible to arrange the control functions in a different order. The function assignment can also be changed by swapping over the connections at the main circuit board. The net result is that the sequence of the receiver outputs is completely „free“, and can be re-arranged to suit your requirements. The position of the connectors on the main circuit board is shown in Fig. 5. The sequence of the auxiliary functions (channels 5 - 8) can also be selected at will.

It is possible to reverse the direction of operation of all channels individually; to do this simply unplug the appropriate connector at the main transmitter circuit board, turn it through 180° and plug it in again. Take care that the connector is actually located on the pins and not to one side of them.

3. RECEIVER AND SERVOS

The F-14 set is supplied complete with the transmitter, an R-168 DF receiver and one S 148 servo, along with various accessories.

Specification

R-168 DF receiver

Functions:	16 / 8 servos
Reception frequency:	40 MHz
Intermediate frequency:	455 kHz
Frequency channels:	22 (40 MHz)
Modulation:	FM (PPM)
Channel spacing:	10 kHz
Supply voltage:	4.8 - 6 V
Current drain:	10 mA
Weight:	25 g
Dimensions:	56 x 29 x 20 mm

S 148 servo

Neutral pulse width:	1.52 ms, pos. pulse
Rotational travel:	2 x 45°
Supply voltage:	4.8 - 6 V
Torque:	30 Ncm = 3.0 kg/cm
Transit time 45°:	0.165 sec
Dimensions:	40.4 x 19.8 x 36.0 mm
Weight:	44.4 g

Connecting the receiving system

The order in which the servos are connected to the receiver varies according to the transmitter stick which you wish to control the various functions. The method of altering the default assignment is described on page 5. If you are a beginner and intend to fly model aircraft we recommend that you keep to the transmitter arrangement (stick mode) which is used by the experienced modellers who fly at your local flying site. This ensures that you will be able to find expert assistance for the first few flights. Fig. 8 shows the arrangement of a typical receiving system.

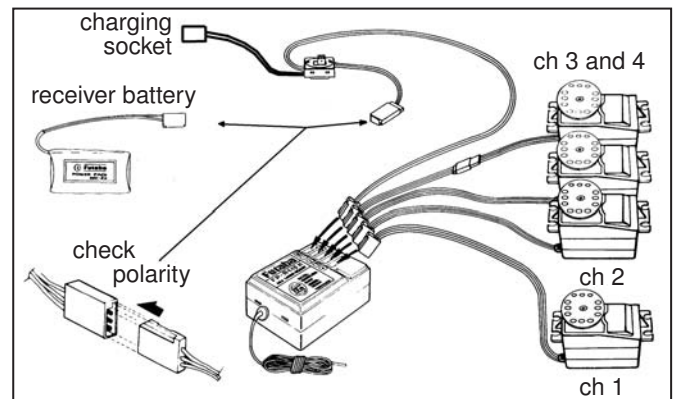

Fig. 8

To keep the drawing comprehensible the drawing only shows the servos for the four basic functions.

Installing the receiving system

The receiver and battery must be packed in thick foam rubber to protect them from the effects of vibration. Make sure that the battery cannot move in flight. You may wish to pack the receiver in a small plastic bag and seal the cable exit with a rubber band or sticky tape to protect it from water, oil or fuel. Take the receiver out of the bag again at the end of the session to avoid harmful condensation forming inside it.

All cables should be routed and deployed in a neat and workmanlike fashion; take care that no wires are under strain or bent at a sharp angle. Don't just run cables haphazardly all round the inside of the model; it is far better to arrange them neatly and tape them to the inside of the fuselage sides.

The receiver aerial must be laid out full-length in as straight a line as possible, and kept as far as you can away from electric motors, servos, high-current cables and metal pushrods.

In model aircraft it is best to run the aerial out of the fuselage by the shortest route and attach it to the fin under light tension using a small rubber band.

Provide some means of strain relief inside the fuselage and run the aerial through a piece of fuel tubing or similar to prevent chafing at the outlet. Fig. 9 shows a typical installation in schematic form.

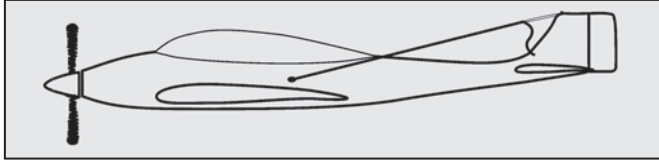

Fig. 9

The receiver aerial must not be shortened, or you will suffer a loss of effective range (see Fig. 10). If the distance to the fin is shorter than the aerial, just allow the excess length to trail freely behind the model. In the case of a CFRP fuselage or a fuselage reinforced with carbon fibre the aerial must be deployed outside the fuselage, and should not even run parallel to the fuselage, as this material shields the signal and can cause reception problems.

Install the receiver switch in such a way that the toggle can be moved to both extremes of travel without obstruction, i.e. the opening in the fuselage side must be big enough. In models powered by a glowplug, diesel or petrol motor the switch should always be fitted on the side opposite to the exhaust, otherwise oil may penetrate and soil the contacts.

If you are using extra-long servo leads, e.g. for aileron servos installed in the wings, the servo leads may pick up a signal and feed interference to the receiver. Wherever servo cables are longer than two normal leads (approx. 50 cm) you should use twisted cables at the very least.

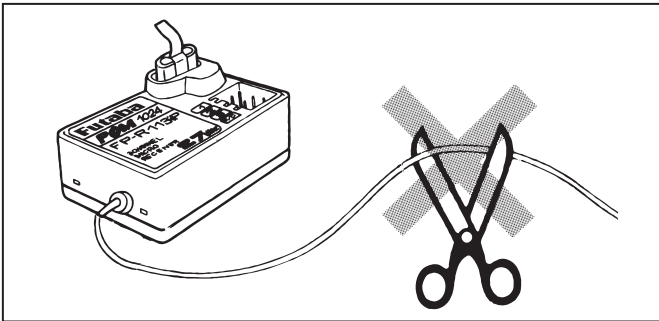

Fig. 10

Even better - use suppressor filters.

In small models it is tempting to leave the aerial coiled up, but this should never be done. It is much better to arrange it on a small plate made of plywood or plastic as shown in Fig. 11, as this does not have a marked influence on effective radio range.

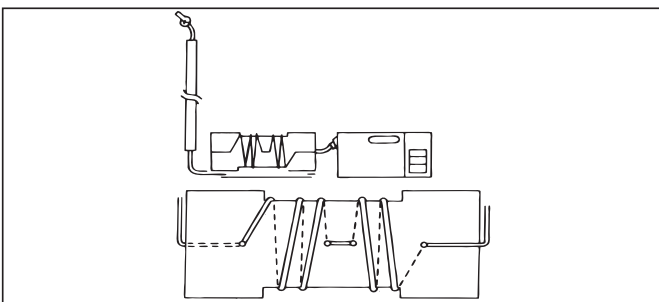

Fig. 11

Always use the rubber grommets and brass eyelets supplied with servos when installing them in the model. Servo retaining screws should be tightened just to the point where the brass eyelets make contact. Don't over-tighten the screws and squeeze the eyelets out of shape, as this would forfeit the damping effect of the rubber grommets. Fig. 12 shows the basic method of installing a servo.

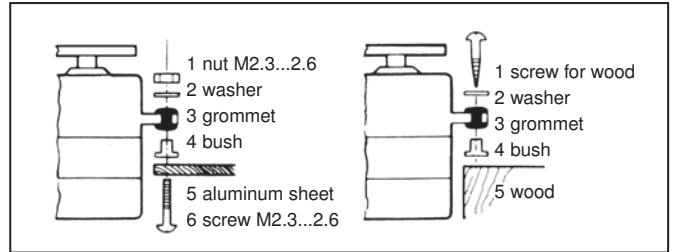

Fig. 12

In model aircraft you will need to fit suitable servo plates or quick-release mounts. In RC model cars servos are usually installed in recesses or openings designed for them. In model boats quick-release servo mounts are a good solution.

Most modern servos feature a splined output shaft, and this makes it possible to adjust the mechanical neutral position of the servo. To do this first undo the output arm retaining screw and remove the output device. Move the output lever to the appropriate position and re-fit the retaining screw. Fig. 13 shows a servo with the pushrod connected. Various servo output arms are available to fit Futaba servos, and Fig. 14 shows the different types. This drawing also shows the effect of moving the output arm round for fine adjustment.

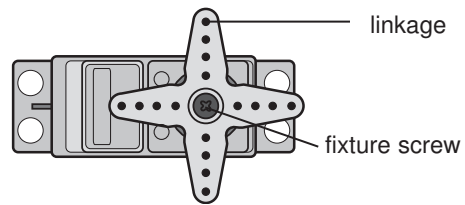

Fig. 13

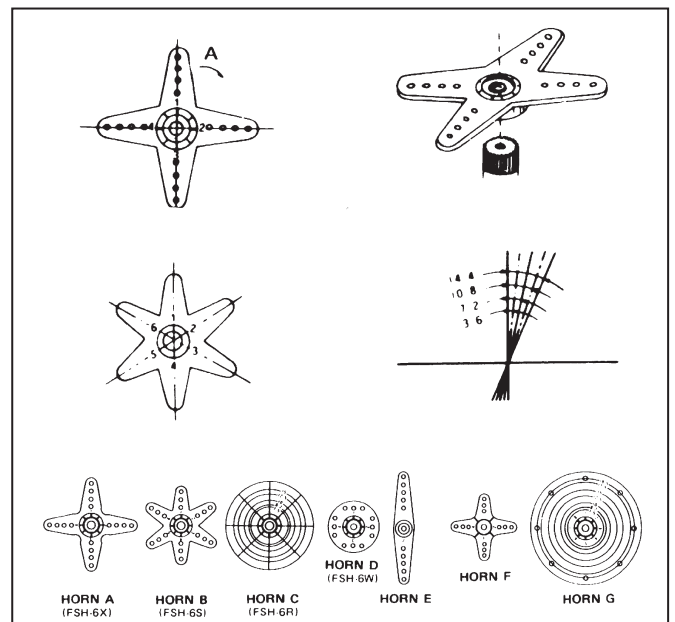

Fig. 14

Receiver power supply

All Futaba receivers continue to work at full range even when the power supply voltage falls to 3 V. The advantage of this feature is that the receiving system will normally continue to work even if one battery cell fails (short-circuit), as Futaba servos also still work down to 3.6 V; they just work more slowly and with lower power. This can be very important in Winter when outdoor temperatures are low, as the system will still work when battery voltage collapses for brief periods.

However, there is a drawback to this flexibility: it is possible that the battery will „lose“ one cell and you will not even notice that there is a problem. To avoid this danger it is important to check the receiver battery from time to time.

The system in use

Always switch the transmitter on first, then the receiver, and reverse the procedure when switching off. When you switch on the transmitter the servos will run to the neutral position. We recommend that you check each function individually by moving the corresponding transmitter stick or associated control. Check also that the control surfaces on the model work in the correct direction. If any system works the wrong way round (e.g. left stick = right rudder), reverse that channel as described earlier.

All servos must be free to work over their full angular travel without any hint of mechanical obstruction by the control surface or the linkage. This is particularly important with regard to the carburettor linkage. The settings „full throttle“ and „idle“ must be determined by the stick positions, and not by the mechanical throttle stop or other obstruction. If this is not the case and the servo is stalled, the servo motor will be under full load virtually constantly, and this will drain the receiver battery dangerously quickly.

As a basic rule the control linkages and control surfaces must be installed and set up in such a way that they move smoothly and with complete freedom. If the linkages are stiff, the servos have to „work harder“, current drain rises and the operating time of the receiver battery will be much reduced. At the same time the control surfaces will not centre accurately, and this makes the model much more difficult to fly smoothly.

If any radio control system is to work reliably it is very important to avoid what is known as electrical „noise“. This can occur, for example, when metal parts such as metal pushrods are allowed to rub against each other under the action of motor vibration. For this reason the linkage to the carburettor should always terminate in a plastic clevis, as a metal link will rattle against the metal carburettor arm. If a metal clevis is unavoidable, insulate the carburettor arm to avoid the metal-to-metal contact.

All electric motors in a model must be suppressed effectively, otherwise the sparking which occurs between armature and carbon brushes produces powerful interference which can prevent the receiver working altogether. We recommend suppressor filters or a set of suppressor capacitors. Each motor must be suppressed individually.

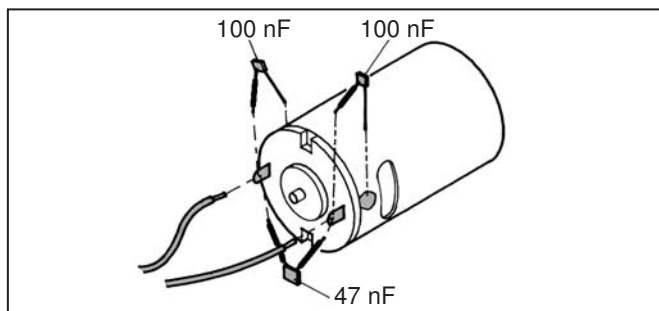

Fig. 15

Fig. 15 shows a typical suppression arrangement of an electric motor.

Always extend the transmitter aerial fully before you start using the system to control a model. When operating your model do not point the transmitter aerial straight at it, as the radiated power of the transmitter aerial is at its lowest in this direction. It is best to stand with the aerial at right-angles to the model. When several radio control systems are in use at the same time, especially when they are on adjacent channels, the operators should always stand together in a loose group. Pilots who insist on standing off to one side endanger both their own model and the models of other pilots.

For safety's sake always carry out a full range check before the first flight of a new model. This is the procedure: collapse the transmitter aerial completely and walk away from the model. At a range of about 60 metres the receiving system should still work without any signs of errors or glitching.

With powered models repeat the range check with the motor running, in case there are vibration problems or interference from the electric motor. On no account try a flight if you are not sure that all is well; seek out and eliminate the problem rather than risk your valuable model.

4. EXPANDING THE TRANSMITTER

Expansion facilities

One of the outstanding features of the F-14 transmitter is that a very comprehensive range of accessories is available which can be fitted at any time. For example, the F-14 is the perfect basis for a special-purpose radio control system for model boats.

1. Linear proportional channel

This slider control has a centre detent and expands the F-14 transmitter by one proportional function. We recommend that it should be connected to one of the pin rows 5 - 8. The direction of servo rotation can be reversed by turning the connector through 180°. The position of the pin row is shown in Fig. 5. Fig. 16 shows a proportional slider unit.

The F-14 transmitter features two installation wells located below the meter, designed to take one proportional channel each. To install a slider you must first remove one of the covers in the centre of the transmitter. To do this lift the corner of the aluminium plate with a sharp knife and lift it off.

The slider unit can then be fitted in the transmitter from the inside and screwed in place on the front. The new cover can then be carefully applied and the knob pushed into place.

3. 3-position switched channel

This switch expands the F-14 transmitter by one switched function, in this case the associated servo can take up any of the following positions: left end-stop, centre, right end-stop. The switch can be connected to any of the pin rows 5 - 8. The direction of servo rotation can be reversed by turning the plug through 180°. The position of the pin row is shown in Fig. 5. Fig. 17 shows a three-position switched channel.

The F-14 transmitter can accept up to four switched channels. To install a switch in option wells 1 - 2 you must first remove

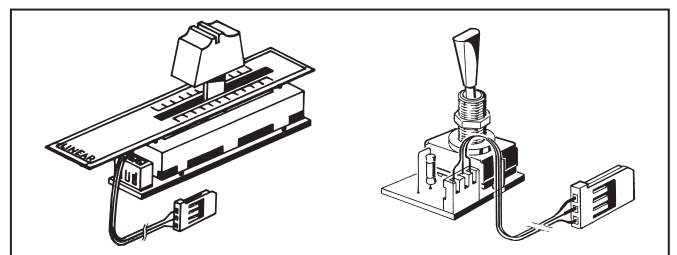

Fig. 16

Fig. 17

the blind cover from the well by undoing the two screws. The switch can then be fitted in the desired location from the inside, and the retaining nut fitted on the outside.

You will need to break out the switch position carefully from the blind cover using a pair of tweezers or pointed-nose pliers before screwing the cover in place again.

2. Multi-Prop module

Fitting this option module for auxiliary functions converts one of the F-14 transmitter's proportional channels 8 servo channels.

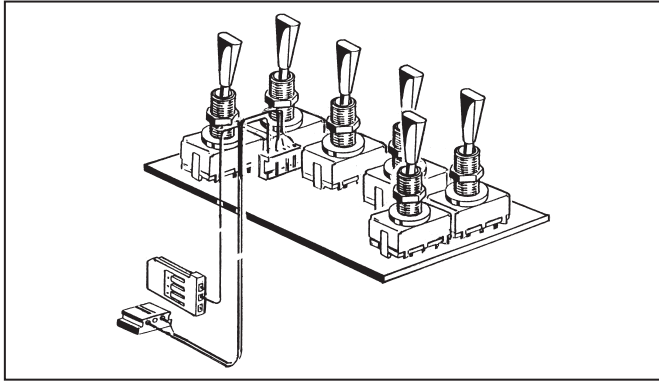

Fig. 18

Mechanical installation of the module simply could not be easier: first remove the cover plate as described earlier, insert it directly into one option well from the rear, then secure it with the nuts supplied. Locate the 3-core cable attached to the module and connect it to the pin row marked „Multi-Out“ on the main transmitter circuit board. Connect the single-core wire to the pin row marked „Multi-In“ 1, 2 or 3.

„Multi-In“ socket	1	2	3
Corresponding receiver output	8	7	6

Do not connect any other transmitter control to the channel you have chosen to use!

The last stage is to re-fit the cover plate after opening up all the holes required. Fig. 19 clearly shows how the module is connected to the main transmitter circuit board.

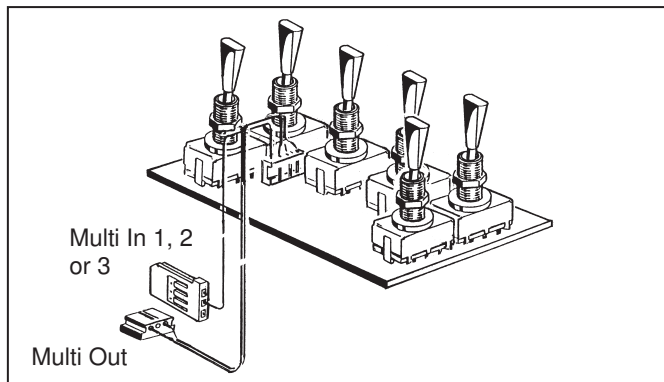

Fig. 19

The module features a large number of switches which could easily be confusing, so we strongly recommend that you write a reminder of each one's purpose on the marker labels, and apply them to the module. Fig. 20 shows how this is done.

The module can only be used if the corresponding decoder is used at the receiving end of the system. The correct decoder is the Multi-Prop decoder which is shown in Fig. 21.

The decoder input must be connected to the receiver output corresponding to the channel to which the Multi-Prop module is connected in the transmitter. Eight servos can be connected to the proportional outputs. For more details of the system please

refer to the operating instructions supplied with the Multi-Prop decoder.

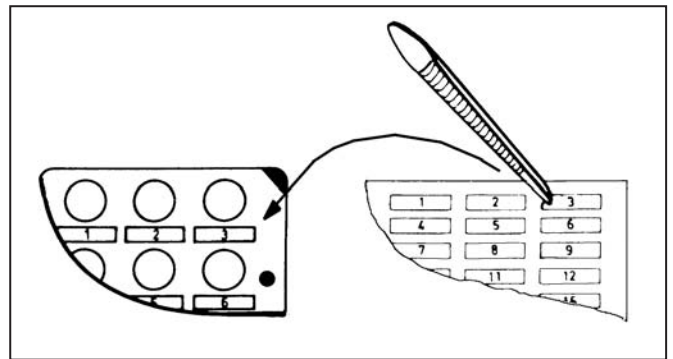

Fig. 20



Fig. 21

3. Multi-Switch 8 module

This module converts one proportional channel at the transmitter into 8 switched functions for auxiliary working systems in the model. The module features two 3-position switches, 3 On/Off switches and 1 momentary switch, and this is sufficient to cope with many applications. Mechanical installation of the module is identical to that of the Multi-Switch-Prop 12 + 2 module. The module can only be used if the corresponding decoder is used at the receiving end of the system. The correct decoder for this module is the Multi-Switch-8 decoder. Connecting the decoder to the receiver and using the decoder are as described for the Multi-Prop decoder.

4. Navy Twin Stick (included in F-14 Navy)

The Navy Twin Stick is shown in Fig. 22; it is a special-purpose parallel stick unit designed for true-scale control of model boats equipped with a twin-motor power system. It can also be used for separate control of mainsail and jib on model boats. The stick functions are of the ratchet (non-centring) type with a centre detent, and have individual superfine trims.



Fig. 22

To install the Twin Stick unit in the transmitter the back panel must first be removed; this procedure is shown in detail in figure 2.

First disconnect the battery cable, then remove the four screws from the front panel which hold the dual-axis stick unit which you wish to replace. The two connecting leads to the main circuit board must then be disconnected. The original stick unit can now be removed from the case and stored in a safe place for possible later use.

Now you can install the Twin Stick unit in its place using the same four screws. Connect the two cables to the sockets on the main circuit board which you have just vacated. Finally seal the trim slider slots in the transmitter case with the adhesive strips provided. The operating instructions provided with the Navy Twin Stick unit include full details of installing, connecting and setting up the unit.



Fig. 23

The F-14 is an extremely flexible and versatile RC system which can be fitted with a wide variety of optional modules.

If you really need all the possible options in terms of modules, switches and adjusters, it is possible to install a Multi-Switch module in the auxiliary option well in the lower section of the transmitter. The only extra part you need is a special cover plate with 6 or 8 openings Fig. 24 shows one of these two covers.



Fig. 24

PERMISSIONS

The Radio Equipment (RED) directive is the new European directive for transmitters and telecommunication devices and their conformity.

This directive governs the import, distribution and use of transmitters within the European Union.

To certify that all applicable European norms are adhered to, the CE sign is attached to all compliant goods. This is applicable for all members of the European Union. Other countries such as Switzerland, Norway, Estonia and Sweden also comply with this directive.



The original declaration of conformity can be found under www.ripmax.com. At the item description, there is a link called „declaration of conformity”.

This product can be operated in all member countries of the European Union. Please note that the responsibility of operating a transmitter that conforms with this directive is the responsibility of the user.

DECLARATION OF CONFORMITY

Ripmax Ltd. declares that this transmitter conforms to all relevant European directives. The original declaration of conformity can be found under www.ripmax.com. At the item description, there is a link called „declaration of conformity”.

RECYCLING



This symbol certifies that electrical and electronic goods are not to be disposed of with normal household waste. Please dispose the item at your local waste collection centre. This applies to all member states of the European Union and all other European countries with separate waste collection schemes.

SERVICE ADDRESSES

country	company	street	city	phone	fax	email
Deutschland	Futaba-Service	Stuttgarter Straße 20/22	D-75179 Pforzheim	0049 -7231-46 94 10		service@rc-service-support.de
Niederlande/Belg.	Jan van Mouwerik	Slot de Houvelaan 30	NL-3155 Maasland	0031-10-59 13 594	0031-10-59 13 594	van_mouwerik@versatel.nl
Österreich	Futaba-Service	Schönbrunner Straße 254	A-1120 Wien	0043 -181 014 64		office@fsoe.at
Schweiz	Futaba-Service	Hinterer Schürmattweg 25	CH-4203 Grellingen	0041- 61 741 23 22		info@robbefutaba-service.ch



Ripmax Ltd.
Ripmax Corner
Green Street
Enfield EN3 7Sj, UK
Tel: +44(0)20 8282 7500
Fax: +44(0)20 8282 7501
Email: mail@ripmax.com
Website: www.ripmax.com

Ripmax GmbH
subsidiary Germany
Futaba RC - Service
Stuttgarter Straße 20/22
75179 Pforzheim
Tel: +49(0)7231 46 94 10
Email: info@rc-service-support.de
Website: www.ripmax.de

Error or technical changes reserved.
Copyright Ripmax 2016
Copy or reprinting - also extracts
- with written permission of Ripmax Ltd. only.



Futaba

powered by
Ripmax

TM-24

FUTABA 2.4 GHz T-FHSS Module F-Series



2.4GHz
T-FHSS

F-14
MULTI-OPTION MODULE SYSTEM

Telemetry System

Item-No. P-FTM-TFH

INSTRUCTION MANUAL

SAFETY INSTRUCTIONS



Please read carefully the safety instructions within the manual of your transmitter!

TM-24 T-FHSS Module

This transmitter module is developed to convert existing Futaba transmitters to the 2.4 GHz frequency band with previous 35/40 MHz transmission frequencies. The following instruction manual explains in detail the connection and operation of the TM-24 Module with the Futaba F-14 transmitter as an example. The connection can be done with almost all transmitters via existing plug connections, but some transmitters require simple soldering. The installation can also be done by our Futaba service against payment.

Installation Of 2.4 GHz Antenna



Two of the switch holes on the front side of the transmitter are required to mount the transmitter antenna. The clear cover plate can remain, only the holes have to be opened.



If the existing holes are already fully occupied with switch / prop modules, the transmitter antenna socket can also be attached to the left or right front of the transmitter. For this, two holes with $D = 6\text{mm}$ must be drilled. The illustrated drilling template can be used for this purpose. (See pictures, also for the status LED).

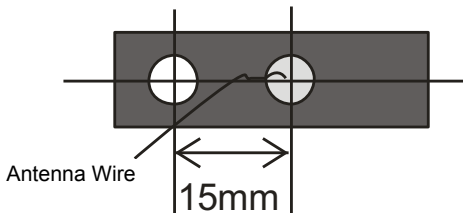

Drilling template for antenna mounting on the front side of the transmitter

Connecting The Module To The Transmitter

For connection, the enclosed adapter cable with PCB is used.

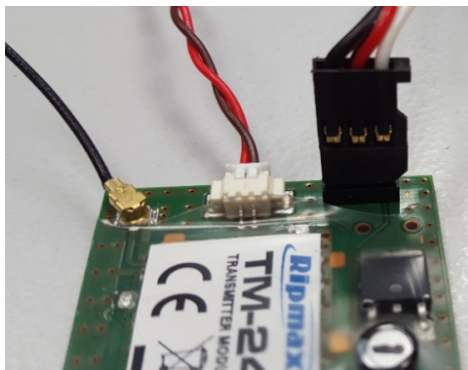

The 3-pin connector (servo plug) of the adapter cable F-14 with additional board is connected to the corresponding plug-in contact (module connection) of the TM-24 module. Observe polarity! The black connecting wire of the plug cable must point inwards towards the module board (minus). It is important to ensure that all 3 contacts are plugged in at all times. The white connection wire must point to the outer edge of the module (signal line).

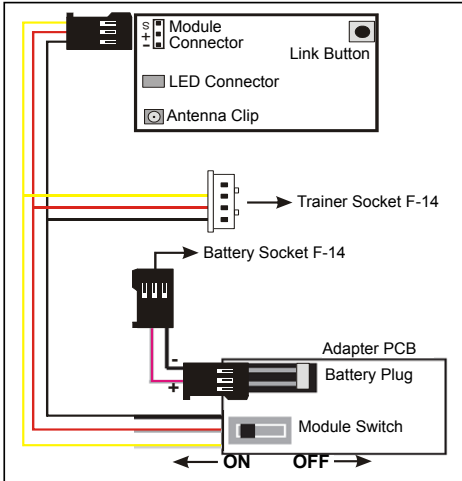

Connection To Transmitter

The signal connector for the TM-24 module is connected to the Trainer socket (4-pin) of the transmitter F-14 using the adapter cable-trainer connector. The plug-in contact is reverse-polarity protected, but do not forcefully press it. One pin of the plug is not used.

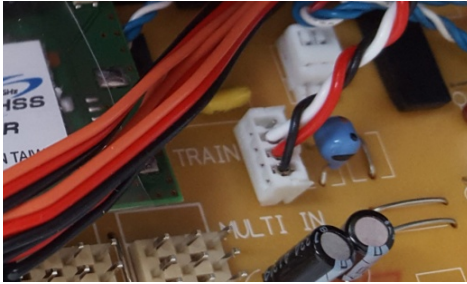

LED Connector

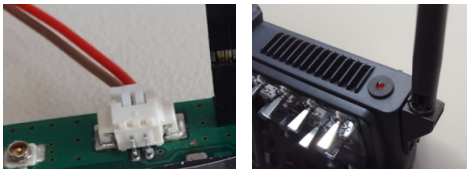

The connector of the LED is connected to the LED connector. It is not possible to reverse the polarity, but it should be done with a little „sensitivity“

in order not to damage the plug.

The LED with bracket is installed either in an existing hole on the switch mounting brackets or as shown in the figure.

Antenna Clip

The antenna cable has a connection clip, the counterpart is seated on the module board (see photo). The clip must be positioned carefully and centrally to the round edge of the clip onto the counterpart (antenna socket) and then depressed carefully until a noticeable snapping action occurs.

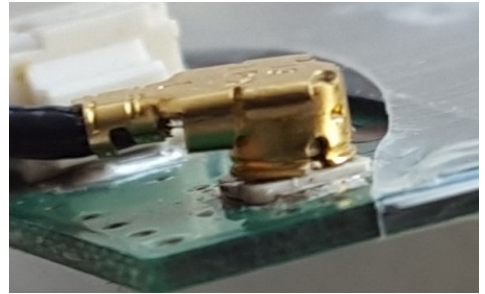

ATTENTION! This is an important task for the safe operation of the F-14, which can have a significant impact on the achievable range and transmission safety, so perform this procedure accurately and correctly.

Connecting To TX Battery

The adapter board allows Futaba TX batteries to be connected to the „old“ plug system and the

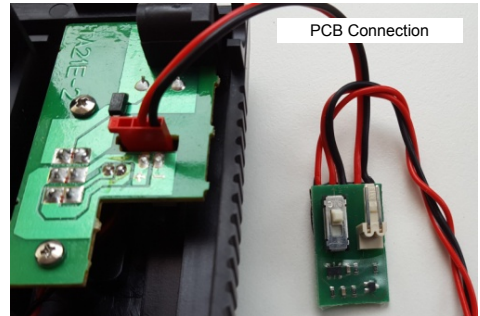

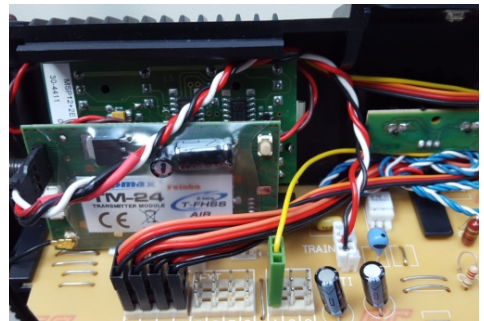
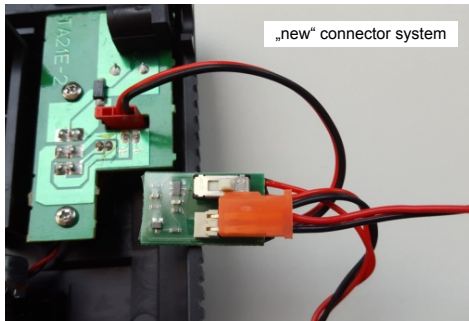
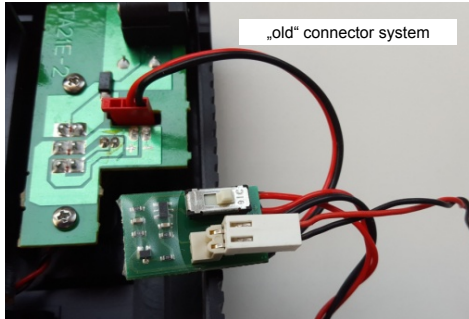

current, standardized plug system.

If a battery is connected with the current plug-in system, please observe polarity (see figure above). The positive pole is located on the side of the switch, one contact remains free.

To operate the TM-24 module, the switch on the adapter board must be set to „ON“ (see connection diagram above). This will power the TM-24 module. For operation, the main switch of the transmitter must be additionally actuated.

Installation Of Module

After all connections have been made, the module has to be attached at a suitable location in the transmitter interior (for example, with double adhesive tape).

Depending on whether multi-switch modules are installed or not, the installation site or the installation type can change. The flat PCB fits virtually anywhere in the transmitter housing.

Binding Procedure

The TM-24 module can be linked and operated with all Futaba T-FHSS receivers or with the TMA-1 telemetry display interface (not included). With the TMA-1 the telemetry data can be displayed on an Android smartphone or tablet.

For first-time operation, a binding process must be carried out between the transmitter (TM-24 module) and the receiver or the TMA-1 module. After that the transmitter module and the receiver or the TMA-1 form a pair, that no other 2.4 GHz transmitter can interfere. The binding process must be carried out only once with each receiver (or TMA-1).

Binding Procedure With T-FHSS Receiver

Preparation: All devices switched OFF. Transmitter ready for use, the battery is connected. Keep the receiver near to the module together with a receiver battery. The link button on the TM-24 module should be easily accessible. An additional servo at the receiver as a function display for the binding process is very helpful.

1. Turn the transmitter ON
2. Push the link button on the TM-24 module for more than 1 second until the red LED flashes once per second.
3. Turn the T-FHSS receiver ON (connect the receiver to the battery).
4. The binding process begins. When the red LED on the TM-24 module and the green LED on the receiver lights up the binding is finished. This can take up to 30 seconds.
5. The servo must now be controllable.

Binding Procedure With TMA-1

Preparation: All devices switched OFF. Transmitter ready for use, the battery is connected. Keep the TMA-1 module near to the module together with the associated power supply (smartphone). The link button on the TM-24 module should be easily accessible.

1. Turn the transmitter ON
2. Push the link button on the TM-24 module for more than 1 second until the red LED flashes once per second.
3. Turn the T-FHSS receiver ON (connect the receiver to the battery).
4. The binding process begins. When the red LED on the TM-24 module and the green LED on the receiver and the TMA-1 light up the binding is finished. This can take up to 30 seconds.
5. Telemetry data can now be viewed by smartphone and the Futaba App. The test servo must be controllable.

Orientation Of The Transmitter Antenna During Model Operation

The transmitting antenna has a directional effect. In practice, this means that the radiation is exactly the same in the direction of the beam. The best antenna position for practical operation is therefore always to orient the antenna slightly obliquely upwards and outwards (see the following picture).



Operating Multiswitch/Multiprop Devices

All suitable extension modules are installed and operated in the transmitter as described in the respective instruction manuals.

The Multi-Switch or Prop-decoders are operated on the Futaba T-FHSS receiver, as described in the respective instructions.

Make sure that the mode switches on the decoder modules are brought into the switch position „PCM“.

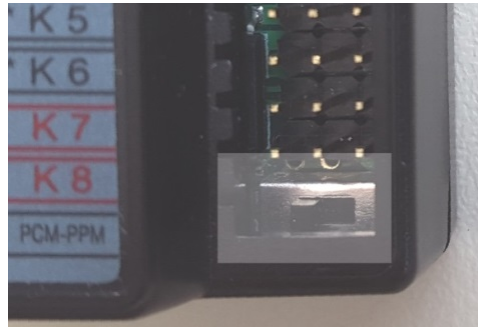

Further Operation Notes

- For operating the transmitter with 2.4 GHz the 40 MHz crystal **MUST** be removed.
- For operating a model with a frequency other than 2.4GHz, e.g. with the built-in 40 MHz transmitter, the TM-24 module must be disabled by turning the switch on the adapter cable to the OFF position.

- The 40 MHz crystal has to be re-installed in this case.
- When the TM-24 module is used in other transmitters than the Futaba F-14, it must have 8 proportional control channels.

For more information, refer to the F-14 remote control manual or the transmitter used, and the instructions for the Multi-Switch or Multi-Prop devices.

Failsafe: Failsafe programming is not possible with this module. When the transmitter signal is missing, the receiver is set to „Hold“ (last valid positions of the channels).

Range Test: A special mode for the range test is not integrated into this module, check regularly the full range (on the ground approx. 500 - 800m) and the perfect function.

Compatible Futaba Transmitters To The TM-24 Module

FC-16, FC-18, FC-28: A suitable adapter is needed, more information can be found on our homepage at www.ripmax.com.

3rd Party Transmitters

It is also possible to equip 3rd party PPM transmitters using 35 or 40 MHz with the module, also more info on our homepage at www.ripmax.com.

Technical Specifications

TM-24 Module 2.4 GHz

Dimension:..... 54x34x9 mm
Weight: 12 Gramm
Frequency:..... 2.4 GHz
Output power:..... 100 mW
Voltage:..... 5-12 V
2.4 GHz-System: T-FHSS w. Telemetry
Current approx.:..... 30 mA

Compatible Futaba Receivers To The TM-24 Module

All Futaba receivers with T-FHSS system (e.g., R3006SB or R3008SB) can be used.

Content TM-24 Module



WARRANTY

Our products are equipped with the statutory 24 months warranty. Should you wish to claim a legitimate warranty claim, please always contact your dealer, the guarantor and the handling department. During this time any malfunctions occurring as well as manufacturing or material errors will be repaired free of charge. Further claims, eg consequential damages, are excluded.

Transport to the service center must be free, the return transport to you is also free. Unfree shipments can not be accepted. We can not accept liability for transport damage or loss of your consignment. We therefore recommend appropriate insurance.

Please send your device to the service center responsible for the country concerned

The following prerequisites must be fulfilled to process your warranty claims:

- Include your shipment receipt (Cash register / invoice copy).
- Operation of the device according to the instruction manual in the non-commercial sector.
- Only recommended power sources and recommended accessories have been used.
- Moisture damage, foreign interference, wrong polarity, overloading and mechanical damages did not occur.
- Include detailed information on the error or the defect.

DISCLAIMER OF LIABILITY

We can not monitor the adherence to the assembly and operating instructions as well as the conditions and methods for the installation, operation, use and maintenance of the remote control components. We therefore accept no liability whatsoever for any loss, damage or expense arising out of or in any way connected with improper use and operation.

In general Ripmax does not assume any liability for the whole function chain „Model“.

Ripmax shall not be liable for any loss, consequential damage, damage or expense arising out

of or in any way connected with improper use and operation.

As far as legally permissible, the obligation of Ripmax to pay damages, irrespective of the legal basis, is limited to the invoice value of the goods of Ripmax directly involved in the event of damages.

APPROVAL PROVISIONS

Directive „RE“ is the European Directive on radio equipment and telecommunications terminal equipment and the mutual recognition of their conformity. The Directive establishes, inter alia, the placing on the market and the putting into service of radio equipment in the European Community.

The CE symbol is affixed as a sign that the devices comply with the valid European standards. This marking is the same for all countries in the European Union. This product can be used in all EU countries and in Switzerland. We would like to draw your attention to the fact that the user is responsible for a radio installation that complies with the guidelines.



DECLARATION OF CONFORMITY

Hereby, Ripmax Ltd. declares that this device is in accordance with the essential requirements and other relevant regulations of the corresponding EU directives. The original declaration of conformity can be found on the Internet at www.ripmax.com, in the respective device description by calling the „Declaration of conformity“ link.

DISPOSAL



This symbol means that electrical and electronic equipment must be disposed of separately from household waste at the end of their useful life. Dispose of the appliance at your local, municipal collection center or recycling center. This applies to all countries of the European Union as well as in other European countries with a separate collection system.

PUT ON THE THE MARKET BY

RIPMAX LTD.
241 Green Street
Enfield, EN3 7SJ
United Kingdom (England)

SERVICE POINTS IN EUROPE



GERMANY
Futaba-Service
Stuttgarter Straße 20/22
D-75179 Pforzheim
Tel.: +49-7231-469 410
E-Mail: service@ripmax.de



AUSTRIA
Futaba-Service
Schönbrunner Straße 254
A-1220 Wien
Tel.: +43-(0)18101464
E-Mail: office@fsoe.at



NETHERLANDS
Jan van Mouwerik
Slot de Houvelaan 30
NL-3155 Maasland
Tel.: +31-10-591 35 94
Fax: +31-10-591 35 94
E-Mail: van_mouwerik@versatel.nl



BELGIQUE
Jan van Mouwerik
Slot de Houvelaan 30
NL-3155 Maasland
Tel.: +31-10-591 35 94
Fax: +31-10-591 35 94
E-Mail: van_mouwerik@versatel.nl



SWITZERLAND
Futaba-Service
Stuttgarter Straße 20/22
D-75179 Pforzheim
Tel.: +49-7231-469 410
E-Mail: service@ripmax.de

RIPMAX GmbH

Stuttgarter Strasse 20/22
D-75179 Pforzheim
Tel.: +49 (0) 72 31 - 4 69 41 0
Mail: info@ripmax.de

SERVICE

Mail: service@ripmax.de
Tel.: +49 (0) 72 31 - 4 69 41 0
Mo.-Do. 10.00-12.00 und 13.00-16.00 Uhr
Fr. 9.00-13.00 Uhr

HOTLINE

Mail: hotline@ripmax.de
Tel.: +49 (0) 72 31 - 4 69 41 29
Mo.-Mi. 9.00-16.00 Uhr
Do. 10.00-18.00 Uhr
Fr. 9.00-14.00 Uhr



Scan the QR code and
install the free app of RIPMAX
on your smartphone / tablet



facebook.com/RipmaxGmbH