

LILLA DAN "578"



BUILDING INSTRUCTION

This model is Copyright protected.
All Copyrights to the designs of this
version of the Lilla Dan belongs to
Krean Holding Aps



www.billingboats.com

DK

SKONNERTEN 'LILLA DAN'.

Originalskibet er bygget på det kendte J. Ring Andersen Værft i Svendborg i 1951 til J. Lauritzen, som anvendte det til skoleskib på rederiets egen søfartsskole Kogtved ved Svendborg. Som byggemateriale er der anvendt eg og bøg.

I dag udlejes LILLA DAN med mandskab til interesserede grupper, og anvendes til møder, konferencer, udflugter eller fester. udlejningsperioden kan variere fra en halv til flere dage, og der sejles udelukkende i de skandinaviske farvande.

GB

THE SCHOONER 'LILLA DAN'.

The original boat is built on the well known shipyard J. Ring Andersen in Svendborg, Denmark, ordered by the shipping company J. Lauritzen in Copenhagen who used it as a training ship for cadets on their navigation school Kogtved near Svendborg.

The building materials mainly used are oak and beech. Nowadays the ship is rented with crew by interested for meetings, conferences, picnics or parties. Such trips can vary from half a day up to a week and are carried out in Scandinavian waters.

D

TOPSEGELSCHONER 'LILLA DAN'.

Die Reederei J. Lauritzen liess den Schoner im Jahre 1951, als Schulschiff für die Reederei-Eigene Seefahrtsschule Kogtved bei Svendborg, bei der bekannten Werft J. Ring Andersen in Svendborg bauen. Als Baumaterial wurde Eiche und Buche verwendet.

Heute wird die LILLA DAN an verschiedenen Interessen Gruppen für einen oder mehrere Tage verchartert. An Bord werden Konferenzen, kurze, Feste oder ganz einfach lange entspannende Vergnügungsturen in den skandinavischen Gewässern abgehalten.

F

LE GOÉLETTE 'LILLA DAN'.

Le bateau original fut construit au Danmark par le chantier J. Ring Andersen, à Svendborg, pour la compagnie maritime J. Lauritzen de Copenhague. Il était utilisé pour l'entraînement des mousses de l'école Kogtved près de Svendborg. Les matériaux utilisés principalement à la construction de bateaux sont le hêtre et le chêne.

Aujourd'hui le bateau et l'équipage sont loués par des entreprises ou des groupes intéressés pour des réunions, des conférences ou des piqués-nique. De tels voyages pouvant durer d'une demi-journée à une semaine, et se déroulent dans les eaux scandinaves.

NL

DE SCHOENER 'LILLA DAN'.

Dit schip werd gebouwd bij de bekende scheepswerf J. Ring Andersen in Svendborg, Denemarken, in opdracht van de rederij J. Lauritzen in Kopenhagen. Deze gebruikte het als opleidingsschip voor de kadetten van hun zeevaarschool Kogtved in de buurt van Svendborg. De in het schip verwerkte houtsoorten zijn hoofdzakelijk eiken en beuken. Tegenwoordig wordt het schip met bemanning verhuurd aan bedrijven en particulieren voor samenkomsten, conferenties, picnics of feestjes e.d. Zulke tochtjes kunnen variëren van een halve dag tot een week en voeren door de Scandinavische kustwateren.

I

LA GOLETTA 'LILLA DAN'.

La nave originale fu costruita nel 1951 nel noto cantiere navale J. Ring Andersen a Svendborg per J. Lauritzen, che la utilizzò come nave-scuola per la scuola marittima della propria compagnia di navigazione Kogtved presso Svendborg. I materiali utilizzati per la costruzione sono il legno di quercia e faggio. Oggi la LILLA DAN viene noleggiata completa di equipaggio a gruppi interessati, e si utilizza per riunioni, conferenze, gite o feste. I periodi di noleggio variano da mezza giornata a diversi giorni, e la navigazione ha luogo unicamente nelle acque della Scandinavia.

E

LA GOLETA "LILLA DAN"

La goleta original fue construida para J. Lauritzen en el famoso astillero de J. Ring Andersen Værft en la ciudad de Svendborg en 1951, y fue utilizada para barco escuela en la propia escuela naval de Kogtved de la casa armadora, situada cerca de Svendborg. La goleta fue construida de roble y haya. Hoy en día, la LILLA DAN se alquila con tripulación a grupos interesados, y se utiliza para celebrar reuniones, conferencias, excursiones o fiestas. El periodo de alquiler puede variar de medio día a varios días, y solamente se navega en los mares escandinavos.

P

A ESCUNA 'LILLA DAN'.

O barco original foi construído no conhecido estaleiro J. Ring Andersen, em Svendborg, em 1951, para a J. Lauritzen, que o utilizou como navio-escola na escola de navegação Kogtved, pertencente à própria armadora, em Svendborg. Os materiais de construção utilizados são carvalho e faia. Hoje em dia, a LILLA DAN pode ser alugada, com tripulação, por grupos de interessados, sendo utilizado para reuniões, convenções, excursões ou festas. O período de arrendamento pode variar de meio dia até vários dias, sendo a área de navegação restrita às águas escandinavas.

Table of contents of 'Lilla Dan' Art No. 578.

No.	Pcs.	Dimension	Material	DK	GB	D	F
1	1	4mm x-veneér	1376L	Spant	Frame	Spant	Couple
2	1	4mm x-veneér	1376L	Spant	Frame	Spant	Couple
3	1	4mm x-veneér	1376L	Spant	Frame	Spant	Couple
4	1	4mm x-veneér	1376L	Spant	Frame	Spant	Couple
5	1	4mm x-veneér	1376L	Spant	Frame	Spant	Couple
6	1	4mm x-veneér	1376L	Spant	Frame	Spant	Couple
7	1	4mm x-veneér	1376L	Spant	Frame	Spant	Couple
8	1	4mm x-veneér	1376L	Spant	Frame	Spant	Couple
9	1	4mm x-veneér	1376L	Spant	Frame	Spant	Couple
10	1	4mm x-veneér	1376L	Spant	Frame	Spant	Couple
11	1	4mm x-veneér	1376L	Spant	Frame	Spant	Couple
12	1	4mm x-veneér	1376L	Spant	Frame	Spant	Couple
13	1	4mm x-veneér	1376L	Spant	Frame	Spant	Couple
14	1	4mm x-veneér	1376L	Stævn	Stem	Steven	Etrave
15	1	4mm x-veneér	1376L	Agterstævn	Stern	Achter Steven	Piece de proué
16	1	4mm x-veneér	1376L	Ror	Rudder	Ruder	Gouvernail
17	1	4mm x-veneér	1376L	Skot	Bulkhead	Schott	Pont
18	1	4mm x-veneér	1376L	Støtte	Supports	Stütze	Support
19	1	4mm x-veneér	1376L	Støtte	Supports	Stütze	Support
20	1	4x10x375mm		Køl	Keel	Kiel	Quille
21	2	4x4x300mm		Kølliste	Keelstrip	Kielleiste	Baquette de quille
22	2	3x5x550mm		Dækstringer	Strip	Deckstringer	Baquette
23	1	2mm x-veneér	2038L-A	Dæk	Deck	Deck	Pont
24	1	2mm x-veneér	2038L-B	Dæk	Deck	Deck	Pont
25	2	1mm x-veneér	2037L	Spuning, front	Auxiliary piece/front	Sponun/Vorn	Piece annexes/front
26	2	1mm x-veneér	2037L	Spuning/agter	Auxiliary piece/aft	Sponung/achtern	Piece annexes/arriere
27	40	1,8x6x550mm	Strip	Beklædning	Plankingstrip	Beplankung	Baquette de borde
28	2	1,8x2x550mm	Strip	Fenderliste	Fensterstrip	Scheuerleiste	Baquette defense
29	2	2mm x-veneér	2038L-A	Naglebænk	Belayingpinbench	Nagelbank	Ratelier cordage
30	2	2mm x-veneér	2038L-A	Naglebænk	Belayingpinbench	Nagelbank	Ratelier cordage
31	2	2mm x-veneér	2038L-B	Ræling	Rail	Reling	Plat-bord
32	2	1mm x-veneér	2037L	Ræling	Rail	Reling	Plat-bord

33	2	1mm x-veneér	2037L	Ræling	Rail	Reling	Plat-bord
34	2	1mm x-veneér	2037L	Ræling	Rail	Reling	Olat-bord
35	40	0,7x3x550mm	Strip	Dæks/kahytliste	Strip f. deck/	Decks-Kajüteleist	Baq. de pont/cabin
36	2	1,8x3x550mm	Strip	Kvadrant-kasse	Quadrant-box	Quadrant-Abdeck	Caisse quadrant
37	1	3x4x550mm	Strip	Kranbjælke	Strip	Kranbalken	Baquette
38	1	5x5x550mm	Strip	Knægt, Bedding	Slip	Knecht/Ständer	Cale
39	1	0,7x2x550mm	Strip	Ristværk	Grating	Buggråting	Grillage
40	1	2x2x200mm	Strip	Til kasse nr.41	For box no. 41	Für Kasten Nr.41	Pour caisse no.41
41	1	20x30x9mm	Block	Kasse	Box	Kasten	Caisse
42	4	1mm x-veneér	2037L	Nedgang	Companion	Niedergang	Ecoutille avant
43	2	12x18x8x8mm	Block	Skylight	Skylight	Oberlicht	Claire voie
44	1	1mm x-veneér	2037L	Mastfod	Maststep	Mastfuss	Support de mât
45	2	1mm x-veneér	2037L	Kahyt	Cabin	Kajüte	Cabine
46	5	1mm x-veneér	2037L	Luge	Hatch	Luke	Ecoutille
47	1	25x39x5mm	Block	Skylight	Skylight	Oberlicht	Claire voie
48	1	18x18x8mm	Block	Skylight	Skylight	Oberlicht	Claire voie
49	5	1mm x-veneér	2037L	Styrhus	Cabin	Steuerhaus	Cabine
50	1	18x9x8mm	Block	Skylight	Skylight	Oberlicht	Claire voie
51	1	17x22x6mm	Block	Skylight	Skylight	Oberlicht	Claire voie
52	1	12x14x8mm	Block	Styrstand	Steering stand	Steuerstand	Gouvernail
53	1	1mm x-veneér	2037L	Dæksel	Cover	Deckel	Couvercle
54	4	0,7x1x550mm	Strip	Dørkarm	Doorframe	Türrahmen	Chambranle
55	1	M3		Bovspryd	Bowsprit	Bugsprit	Baupre
56	1	M10		Undermast	Mast	Untermast	Mât
57	1	M11		Mærsstang	Mast	Maststenge	Mât
58	1	M10		Undermast	Mast	Untermast	Mât
59	1	M11		Stang	Mast	Stenge	Mât
60	1	R5		Fokkerå	Yard	Fockrah	Vergue
61	1	R5		Mærsrå	Yard	Marsrah	Vergue
62	1	R3		Bramrå	Yard	Bramrah	Vergue
63	1	M0		Fokkeboom	Boom	Fockbaum	Bôme
64	1	M0		Fokkegaffelboom	Boom	Fockgaffelbaum	Bôme
65	1	M2		Storbom	Boom	Grossbaum	Bôme
66	1	M1		Storgaffelboom	Boom	Grossgaffelbaum	Bôme

67	1	2mm x-veneér	2038L-A	Spil	Winch	Winde	Treuil
68	2	2mm x-veneér	2038L-A	Spil	Winch	Winde	Treuil
	1	Bag		Søm	Pins	Nägel	Clous
	1			Transfer	Transfers	Abziehbild	Decals
	1			Flag	Flag	Flagge	Drapeau
	1			Sejlstof	Sailcloth	Segelstoff	Tisseu de voile
	1	A4		Byggevejledning	Building instr.	Bauanleitung	Instr. de montage
	3			Tegninger	Plans	Zeichnungen	Plans
F6	1		Brass	Skorsten	Funnel	Schornstein	Cheminée
F9	4	15mm	Plastic	Redningsbælte	Lifebelts	Rettungsringe	Bouée
F17	1	20mm	Brass	Bombeslag	Barfitting	Baumbeschlag	Garniture de bome
F21	18		Brass	Vantskruer	Turnshouds	Wantenschrauben	Ridoirs
F22a	1	ø0,5mm	Copper	Kobbertråd	Copperthread	Kupferdraht	Fil de cuivre
F28	2	ø10x33mm	Plastic	Ventiler	Vent	Lüfter	Manche á air
F34	2	23x9x7mm	Plastic	Lanternekasser	Board f.sidelight	Laternenkasten	Plancette pour feux
F37	1	28x15x7mm	Plastic	Anker	Anchor	Anker	Ancre
F 37-1	1	3x5x34mm	Plastic	Ankerstok	Stock	Stock	Jas
F39	1	250x1mm	Brass	Messingtråd	Brasswire	Messingdraht	Fil de laiton
F40	1	28mm	Plastic	Skrue	Propeller	Schiffschrauben	Hélice
F41	4	12mm	Plastic	Klyds	Open chock	Klüsen	Ecubiérs
F51	1	ø24mm	Brass	Rat	Wheel	Steuerrad	Roue
F52	1	ø9mm	Plastic	Kompas	Compass	Kompas	Compas
F54	58	8mm		Kofilnagler	Belaying pins	Belegnägel	Cabillots
F56	1	ø5x5,5mm	Brass	Klokke	Bell	Glocke	Cloche
F57	1	35mm	Plastic	Anker	Ancor	Anker	Ancre
F57-1	1	35mm	Plastic	Ankerstok	Stock	Stock	Jas
F60	2	20mm	Plastic	Ventiler	Vent	Lüfter	Manche á air
F64/1	80	3x5mm	Plastic	Enkelte blokke	Single blocks	Einfache Blöcke	Poulies simples
F64/2	12	4x5mm	Plastic	Dobbelt blokke	Double blocks	Einfache Blöcke	Poulies simples
F66	10	ø6mm	Plastic	Køøjer	Portlight	Bullaugen	Hublot
F67	6	ø5mm	Plastic	Køøjer	Portlight	Bullaugen	Hublot
F70	1 rl.	30m		Rigningstråd	Riggingthread	Takelgarn	Fil de gréement
F71	1 rl.	50m		Rigningstråd	Riggingthread	Takelgarn	Fil de gréement
F72	1 rl.	30m		Rigningstråd	Riggingthread	Takelgarn	Fil de gréement

F112	4	ø5x6mm	Brass	Pullert	Bollard	Poller	Bitte d'armarrage
F116	1	ø4mm	Brass	Skorsten	Funnel	Schornstein	Cheminée
F117	1	ø4mm	Brass	Skorsten	Funnel	Schornstein	Cheminée
F121/F123	4	ø6x7,5mm	Brass	Lanterne	Bowlight	Laterne	Feux de navigation
F122	1		Brass	Spil	Winch	Winde	Treuil
F124	2	ø3x40mm	Brass	Messingrør	Brass pipes	Messingrohr	Tuyaux en laiton
F124-1	2	ø3x80mm	Brass	Messingrør	Brass pipes	Messingrohr	Tuyaux en laiton
F170	1	64mm	Plastic	Redningsbåd	Lifeboat	Rettungsboot	Chaloupe pontée
F183	18	ø12mm	Plastic	Sejlring	Sail hoop	Segelring	Cercel de voiles
F185	8	ø9mm	Plastic	Sejlring	Sail hoop	Segelring	Cercel de voiles
F188	2	ø5x2mm	Brass	Ring	Ring	Ring	Anneau
F285	4	5,5mm	Brass	Øjebolt	Eyebolt	Augenbolzen	Pitons
F296	1	ø1,5x20mm	Brass	Aksel	Propeller shaft	Achse	Arbre port hélice
F299	8	ø2x23mm	Brass	Gelænderstøtte	Rail stanchion	Geländerstützen	Chandellers
F327	1	250mm	Brass	Ankerkæde	Chain	Kette	Chaine
F348	2	2x5x9mm	Plastic	Klampe	Cleat	Klampen	Taquets
F379	2	ø5x1,8mm	Brass	Koniske skiver	Conical disks	Konische Scheiben	Disques en cône
F498	1	0,7x11x22mm	Brass	Råbeslag	Yard fitting	Rahbeschlag	Garniture de vergue
F499	1	ø3x8,5mm	Brass	Råbeslag	Yard fitting	Rahbeschlag	Garniture de vergue
F526	1	ø9x2mm	Brass	Mastring	Mast fitting	Mastbeschlag	Garniture de mât
F537	2	25mm	Brass	Røstjern	Chain plate	Rüsteisen	Cadene
F651	2	ø7x0,8mm	Plastic	Håndhjul	Handle	Handrad	Mainevelle
F663	3	ø0,8x250mm	Brass	Messingtråd	Brasswire	Messingdraht	Fil de laiton
F664	60	11mm	Copper	Øjebolt	Eyebolt	Augenbolzen	Pitons
F766	1	ø11x19mm	Brass	Redningsflåde	Lifeaft	Rettungsinsel	Radeau sauvetage
F782	1		Plastic	Plastikstøb	Plastic fittings	Plastikguss	Garniture plastic

Table of contents of 'Lilla Dan' Art No. 578.

No.	Pcs.	Dimension	Material	NL	E	P	
1	1	4mm x-veneér	1376L	Spant	Cuderna	Ordinata	Armação
2	1	4mm x-veneér	1376L	Spant	Cuderna	Ordinata	Armação
3	1	4mm x-veneér	1376L	Spant	Cuderna	Ordinata	Armação
4	1	4mm x-veneér	1376L	Spant	Cuderna	Ordinata	Armação
5	1	4mm x-veneér	1376L	Spant	Cuderna	Ordinata	Armação

6	1	4mm x-veneér	1376L	Spant	Cuderna	Ordinata	Armação
7	1	4mm x-veneér	1376L	Spant	Cuderna	Ordinata	Armação
8	1	4mm x-veneér	1376L	Spant	Cuderna	Ordinata	Armação
9	1	4mm x-veneér	1376L	Spant	Cuderna	Ordinata	Armação
10	1	4mm x-veneér	1376L	Spant	Cuderna	Ordinata	Armação
11	1	4mm x-veneér	1376L	Spant	Cuderna	Ordinata	Armação
12	1	4mm x-veneér	1376L	Spant	Cuderna	Ordinata	Armação
13	1	4mm x-veneér	1376L	Spant	Cuderna	Ordinata	Armação
14	1	4mm x-veneér	1376L	Vorsteven	Trasera	Ruota di prua	Proa
15	1	4mm x-veneér	1376L	Achtersteven	Roda trasera	Dritto di poppa	Cadaste
16	1	4mm x-veneér	1376L	Roer	Timón	Timone	Leme
17	1	4mm x-veneér	1376L	Schot	Manpara	Paratia	Paredes divisórias
18	1	4mm x-veneér	1376L	Steunen	Soporto	Supporto	Suporte
19	1	4mm x-veneér	1376L	Steunen	Soporto	Supporto	Suporte
20	1	4x10x375mm		Kiel	Quilla	Listello	Tiras
21	2	4x4x300mm		Kielstrip	Liston de quilla	Listello	Tiras
22	2	3x5x550mm		Strip	Liston	Listello	Tiras
23	1	2mm x-veneér	2038L-A	Dek	Cubierta	Ponte	Deck
24	1	2mm x-veneér	2038L-B	Dek	Cubierta	Ponte	Deck
25	2	1mm x-veneér	2037L	Hulpstukken/front	Alefriz/fronto	Rinforzo, anteriore	Ensambladura, proa
26	2	1mm x-veneér	2037L	Hulpstukken/achtern	Alefriz/Popa	Rinforzo, posteriore	Ensambladura, popa
27	40	1,8x6x550mm	Strip	Bekledningstrip	Forro	Listello	Tiras
28	2	1,8x2x550mm	Strip	Strip vor stootkus.	Como de cojin	Listello	Tiras
29	2	2mm x-veneér	2038L-A	Naglebank	Cabilleros	Cavigliera	Pino da amurada
30	2	2mm x-veneér	2038L-A	Naglebank	Cabilleros	Cavigliera	Pino da amurada
31	2	2mm x-veneér	2038L-B	Reling	Borda	Parapetto	Amurada de popa
32	2	1mm x-veneér	2037L	Reling	Borda	Parapetto	Amurada de popa
33	2	1mm x-veneér	2037L	Reling	Borda	Parapetto	Amurada de popa
34	2	1mm x-veneér	2037L	Reling	Borda	Parapetto	Amurada de popa
35	40	0,7x3x550mm	Strip	Strip v. dek/kajuit	Liston p. cubierta/camarote	Listello	Tiras
36	2	1,8x3x550mm	Strip	Strip	Liston	Listello	Tiras
37	1	3x4x550mm	Strip	Strip	Liston	Listello	Tiras
38	1	5x5x550mm	Strip	Standaard	Grada	Listello	Tiras
39	1	0,7x2x550mm	Strip	Roosterwerk	Emparillado	Listello	Tiras

40	1	2x2x200mm	Strip	Voor kisten no.41	Para caja no. 41	Listello	Tiras
41	1	20x30x9mm	Block	Kist	Caja	Cassa	Caixa
42	4	1mm x-veneér	2037L	Campagne	Bajada	Scaletta boccaporto	Declinar
43	2	12x18x8x8mm	Block	Bovenlicht	Lumbrera	Osteriggio	Clarabóia
44	1	1mm x-veneér	2037L	Mastvoet	Herrajes de palo	Piede d'albero	Degrau do mastro
45	2	1mm x-veneér	2037L	Kajuit	Camarote	Cabina	Cabine
46	5	1mm x-veneér	2037L	Luike	Escotilla	Boccaporto	Bloco da escotilha
47	1	25x39x5mm	Block	Bovenlicht	Lumbrera	Osteriggio	Clarabóia
48	1	18x18x8mm	Block	Bovenlicht	Lumbrera	Osteriggio	Clarabóia
49	5	1mm x-veneér	2037L	Stuurhuis	Camarote	Cabina di pilotaggio	Cabine
50	1	18x9x8mm	Block	Bovenlicht	Lumbrera	Osteriggio	Clarabóia
51	1	17x22x6mm	Block	Bovenlicht	Lumbrera	Osteriggio	Clarabóia
52	1	12x14x8mm	Block	Stuurkolom	Timón	Posto di comando	Bloco (di Timão)
53	1	1mm x-veneér	2037L	Deksel	Tapa	Coperchio	Cobertura
54	4	0,7x1x550mm	Strip	Strip	Liston	Listello	Tiras
55	1	M3		Boegspriet	Baupres	Albero di bompresso	Gurupés (mastro de próa)
56	1	M10		Masten	Palo	Albero	Mastro
57	1	M11		Masten	Palo	Albero	Mastro
58	1	M10		Masten	Palo	Albero	Mastro
59	1	M11		Masten	Palo	Albero	Mastro
60	1	R5		Ra	Verga de trinquete	Pennone	Verga
61	1	R5		Ra	Verga de cofa	Pennone	Verga
62	1	R3		Ra	Verga	Pennone	Verga
63	1	M0		Bomen	Botavara	Albero di maestra	Botaló principal
64	1	M0		Bomen	Botavara	Albero di maestra	Botaló principal
65	1	M2		Bomen	Botavara	Albero di maestra	Botaló principal
66	1	M1		Bomen	Botavara	Albero di maestra	Botaló principal
67	1	2mm x-veneér	2038L-A	Winch	Chigre	Verricello	Guincho
68	2	2mm x-veneér	2038L-A	Winch	Chigre	Verricello	Guincho
	1	Bag		Spijkertjes	Clavo	Chiodi	Pino
	1			Transfers	Transfer	Decalcomanie	Transfers
	1			Vlag	Bandera	Bandiere	Bandeira
	1			Zeildoek	Vela	Vela	Velas
	1	A4		Bouwbeschrijving	Indicacion de constr.	Istruzioni di montaggio	Instruções du montagem

	3			Bouwtekeningen	Dijubo	Piani di costruzione	Planta principal
F6	1		Brass	Schoorsteen	Chimenea	Camino	Chaminé
F9	4	15mm	Plastic	Reddingsboie	Cinturones salvavidas	Cintura di salvataggio	Bóias salva-vidas
F17	1	20mm	Brass	Lummel	Herrajes de botavara	Accessorio per albero	Ferragens do mastro
F21	18		Brass	Wantspanners	Opresor	Tiranti a vite	Tirante
F22a	1	ø0,5mm	Copper	Koperdraad	Alambre de cabre	Filo in rame	Linha de cobre
F28	2	ø10x33mm	Plastic	Luchtkoker	Vávula	Valvola	Respiradouro
F34	2	23x9x7mm	Plastic	Lichtbakken	Cajas para linternas	Cassa lanterna	Suporte da luz lateral
F37	1	28x15x7mm	Plastic	Anker	Ancla	Ancora	Âncora
F 37-1	1	3x5x34mm	Plastic	Stok	Cepo	Ceppo	Ceppo de ferro
F39	1	250x1mm	Brass	Messingdraad	Hilo de latón	Filo in ottone	Tubo do guincho
F40	1	28mm	Plastic	Schroet	Hélice	Elica	Hélice
F41	4	12mm	Plastic	Verhaalklampen	Bobina	Rinforzo	Tubo do escovém
F51	1	ø24mm	Brass	Stuurwiel	Volante	Ruota del timone	Volante do timão
F52	1	ø9mm	Plastic	Kompas	Brújula	Bussola	Compasso
F54	58	8mm		Korvijnnagels	Cabillas	Ribattino	Pino de amarração
F56	1	ø5x5,5mm	Brass	Scheepsbel	Campanilla	Campana	Sino
F57	1	35mm	Plastic	Anker	Ancla	Ancora	Âncora
F57-1	1	35mm	Plastic	Stok	Cepo	Ceppo	Ceppo de ferro
F60	2	20mm	Plastic	Luchtkoker	Vávula	Valvola	Respiradouro
F64/1	80	3x5mm	Plastic	Enkel blok	Polea simple	Blocchi (semplici)	Blocos simples
F64/2	12	4x5mm	Plastic	Enkel blok	Polea simple	Blocchi (doppi)	Blocos duplos
F66	10	ø6mm	Plastic	Patrjspoort	Potillas	Obló	Aro de escotilha
F67	6	ø5mm	Plastic	Patrjspoort	Potillas	Obló	Aro de escotilha
F70	1 rl.	30m		Takelgaren	Hilo de oparejo	Filo per manovre	Linha de cordame
F71	1 rl.	50m		Takelgaren	Hilo de oparejo	Filo per manovre	Linha de cordame
F72	1 rl.	30m		Takelgaren	Hilo de oparejo	Filo per manovre	Linha de cordame
F112	4	ø5x6mm	Brass	Bolder	Pollare	Bitta	Poste de amarração
F116	1	ø4mm	Brass	Schoorsteen	Chimenea	Camino	Chaminé
F117	1	ø4mm	Brass	Schoorsteen	Chimenea	Camino	Chaminé
F121/F123	4	ø6x7,5mm	Brass	Boordlichten	Linternas	Lanterna di bordo	Luzes
F122	1		Brass	Winch	Chigre	Verricello	Guincho
F124	2	ø3x40mm	Brass	Messingbeslag	Tubo de latón	Tubo in ottone	Tubo de latão
F124-1	2	ø3x80mm	Brass	Messingbeslag	Tubo de latón	Tubo in ottone	Tubo de latão

F170	1	64mm	Plastic	Reddingboie	Bote salvavida	Battello di salvataggio	Barco salva-vidas
F183	18	ø12mm	Plastic	Zeilbeslag	Herrejas de vela	Accessori	Fixador do ovém
F185	8	ø9mm	Plastic	Zeilbeslag	Herrejas de vela	Anello	Anel
F188	2	ø5x2mm	Brass	Ring	Herrejas	Bullone ad occhio	Ferrolho
F285	4	5,5mm	Brass	Oogbauten	Pernos de cánamo	Bullone ad occhio	Ferrolho
F296	1	ø1,5x20mm	Brass	Schoefas	Je de hélice	Supporti per corrimano	Pontaete da amurada
F299	8	ø2x23mm	Brass	Railingspalen	Soporto de pasamanos	Catena ancora	Corrente da âncora
F327	1	250mm	Brass	Ketting	Cadena de ancla	Galloccia	Ponto de amarra
F348	2	2x5x9mm	Plastic	Kikkerts	Cornamusas	Disco conico	Disco cônico
F379	2	ø5x1,8mm	Brass	Schijt	Disco cónico	Disco conico	Disco cônico
F498	1	0,7x11x22mm	Brass	Rabeslag	Herrejas para verga	Accessori	Fixador do ovém
F499	1	ø3x8,5mm	Brass	Rabeslag	Herrejas para verga	Accessori	Fixador do ovém
F526	1	ø9x2mm	Brass	Mastbeslag	Herrejas para palo	Anello dell'albero	Topo do Mastro
F537	2	25mm	Brass	Puttingfizers	Cadenote	Landra	Fixador da corda do mastro
F651	2	ø7x0,8mm	Plastic	Handspaak	Volante	Verricello manuale	Guincho manual
F663	3	ø0,8x250mm	Brass	Messingdraat	Hilo de latón	Filo in ottone	Tubo do guincho
F664	60	11mm	Copper	Oogbauten	Pernos de cánamo	Bullone ad occhio	Ferrolho
F766	1	ø11x19mm	Brass	Reddingvlot	Balsa salvavida	Zattera di salvataggio	Salva-vidas
F782	1		Plastic	Plastikbeslag	Herrajes de plastico	Pezzo stampato a iniezione	Plástico moldado

Symboler  = Farvenummer

 = Colour No.

 = Farben Nr.

Symboles  = Couleur no.

 = Kleur Nr.

 = Color Nr.

Segno  = Colore N°

 = Cõr n°

Til denne model er mahogni bejdse og farver med følgende numre nødvendige:

For this model is mahogany stain and colours with the following numbers should be used:

Für dieses Modell sind Mahagoni Beize und Farben mit den folgenden Nummern notwendig:

Pour ce modèle, le mordant et les couleurs avec les numéros suivants doivent être employées:

Voor dit model zijn kleuren met de volgende nummers nodig:

Para est modelo se necesitan mordiente et colores con los siguientes números:

Per questo modello occorrono inchiostro tinggiatore "mogano" e colori con questi numeri:

Pinte o modelo com tintura cõr Mogno e as cõres sugeridas da Billing Boats:

Billing	1	=	White
Billing	3	=	Emerald
Billing	9	=	Bright red
Billing	11	=	Black
Billing	12	=	Pale grey
Billing	13	=	Trainer yellow
Billing	15	=	Silver
Billing	16	=	Gold
Billing	33	=	Matt mid green
Billing	36	=	Bejdse/Stain/Beize/Mordant/Beize/Mordient

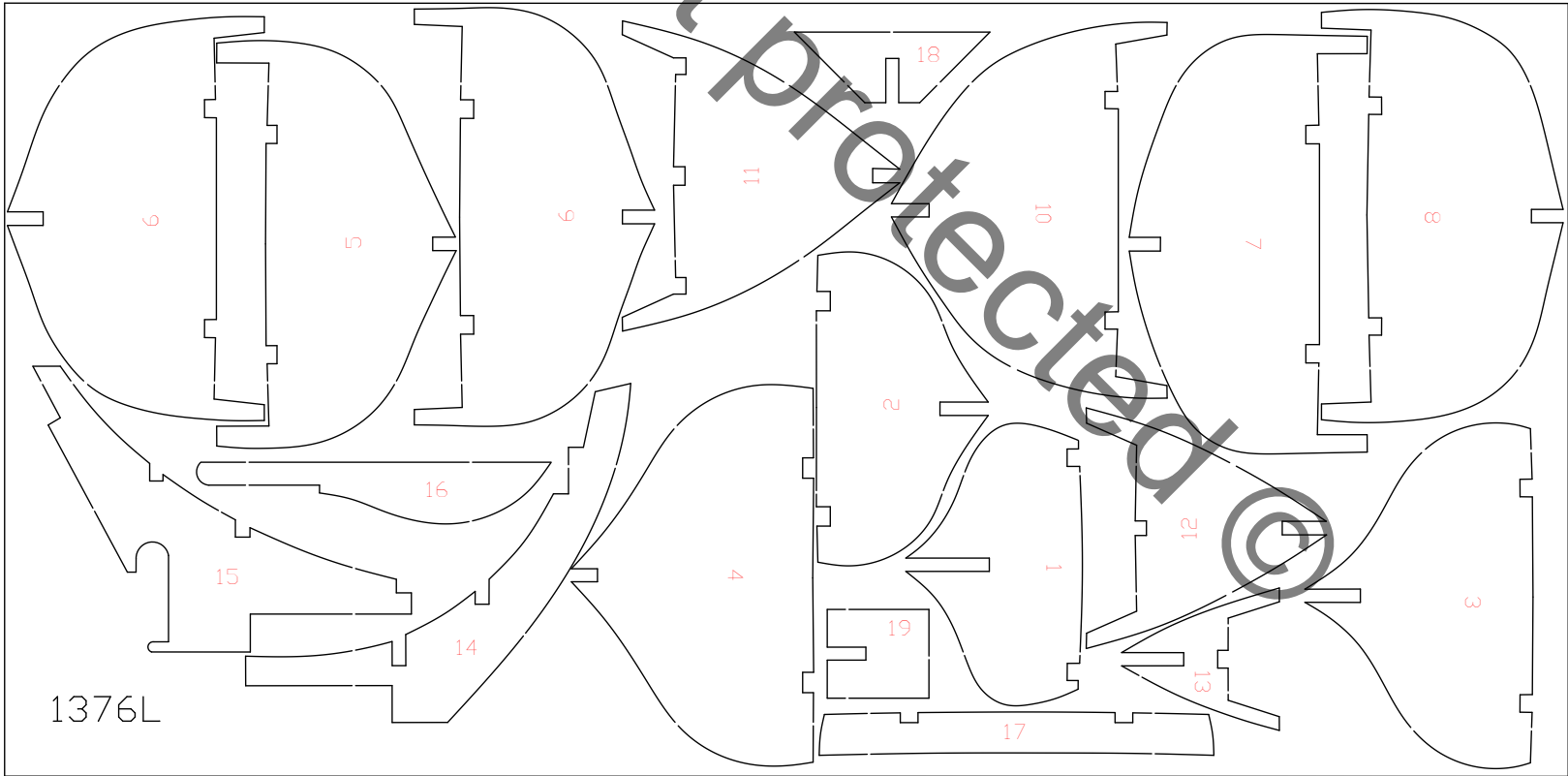
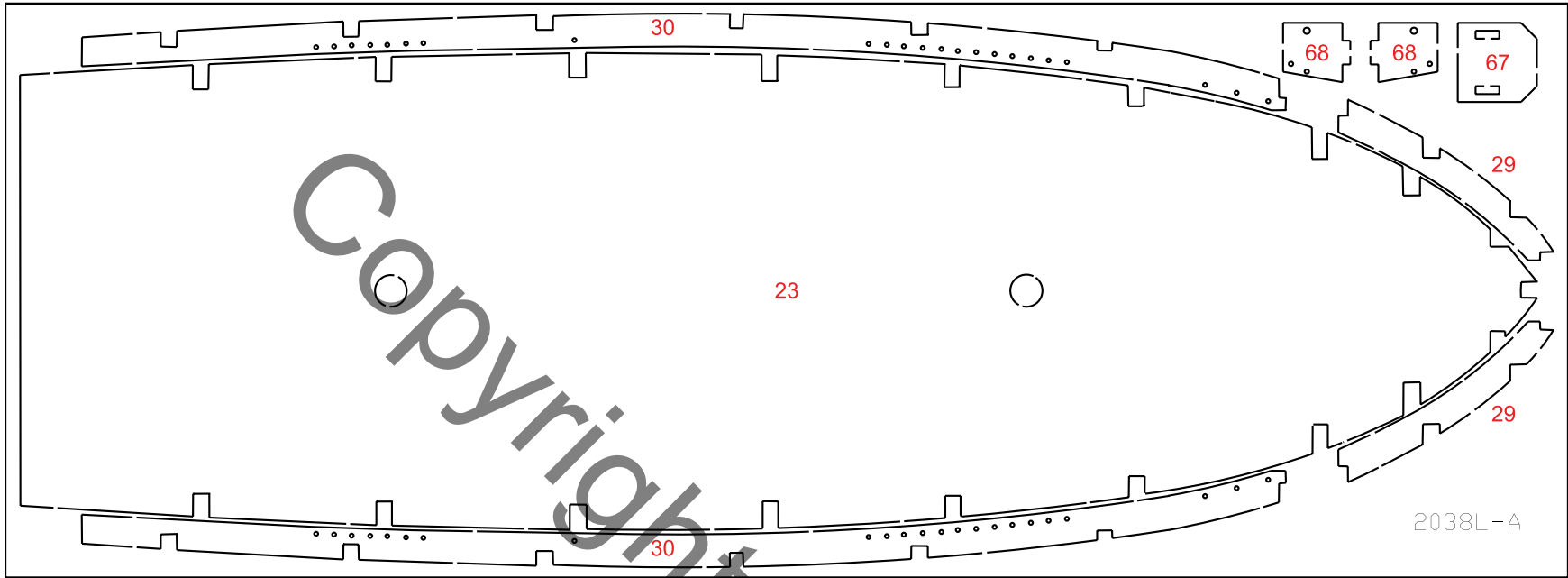

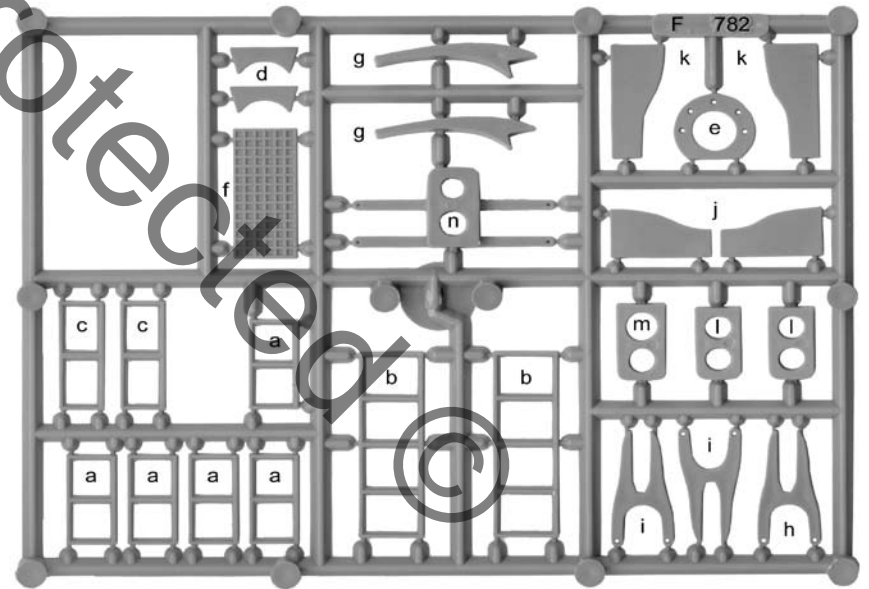
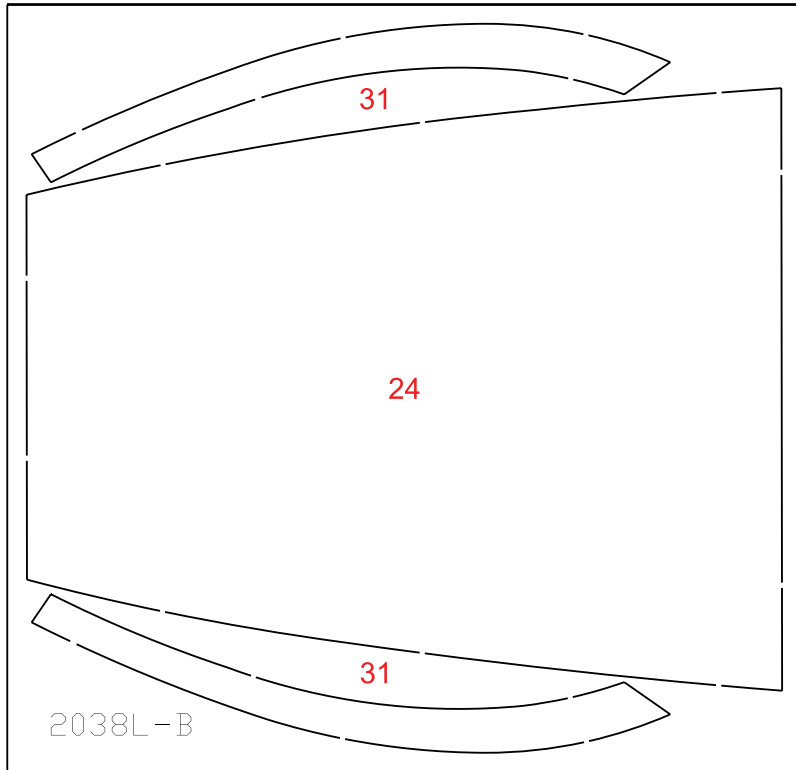
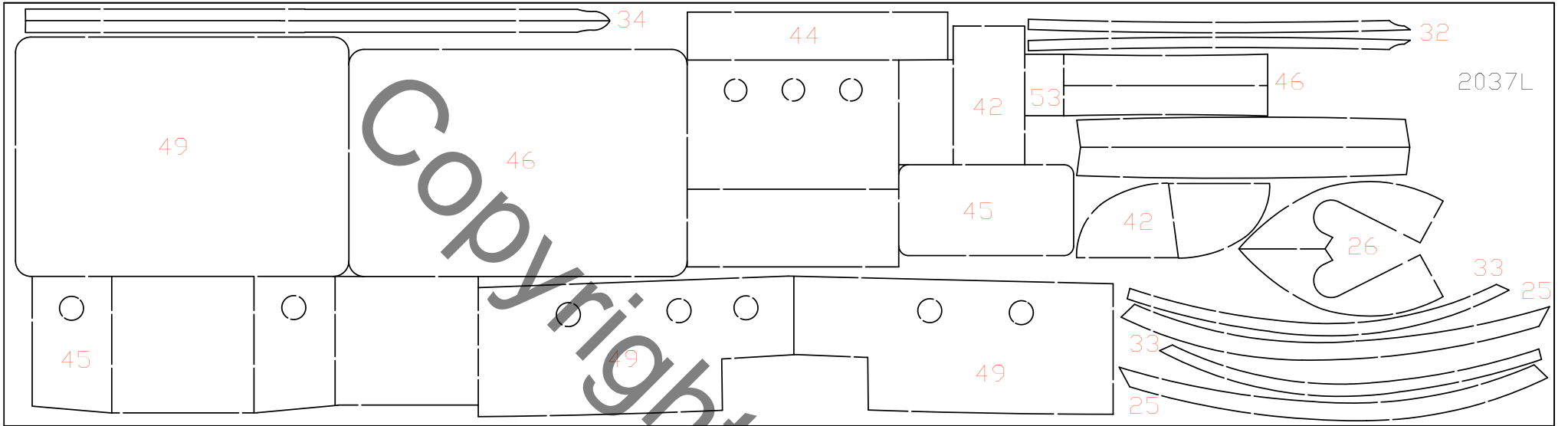

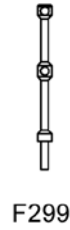
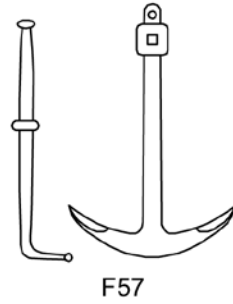
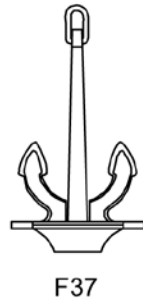
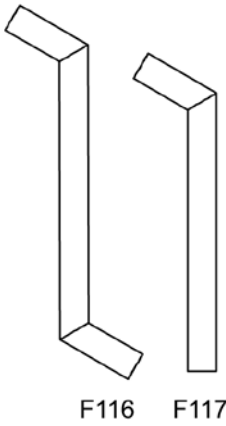
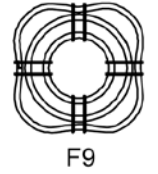
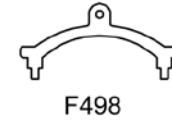
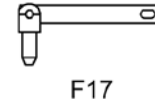
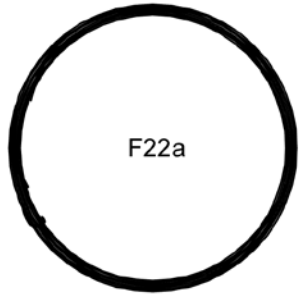
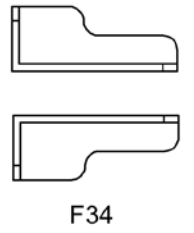
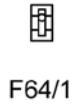
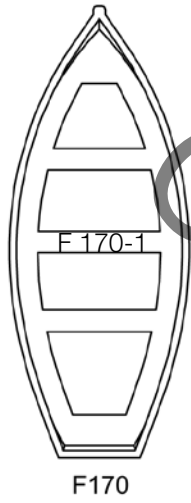
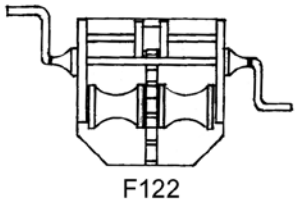

Fig. 1

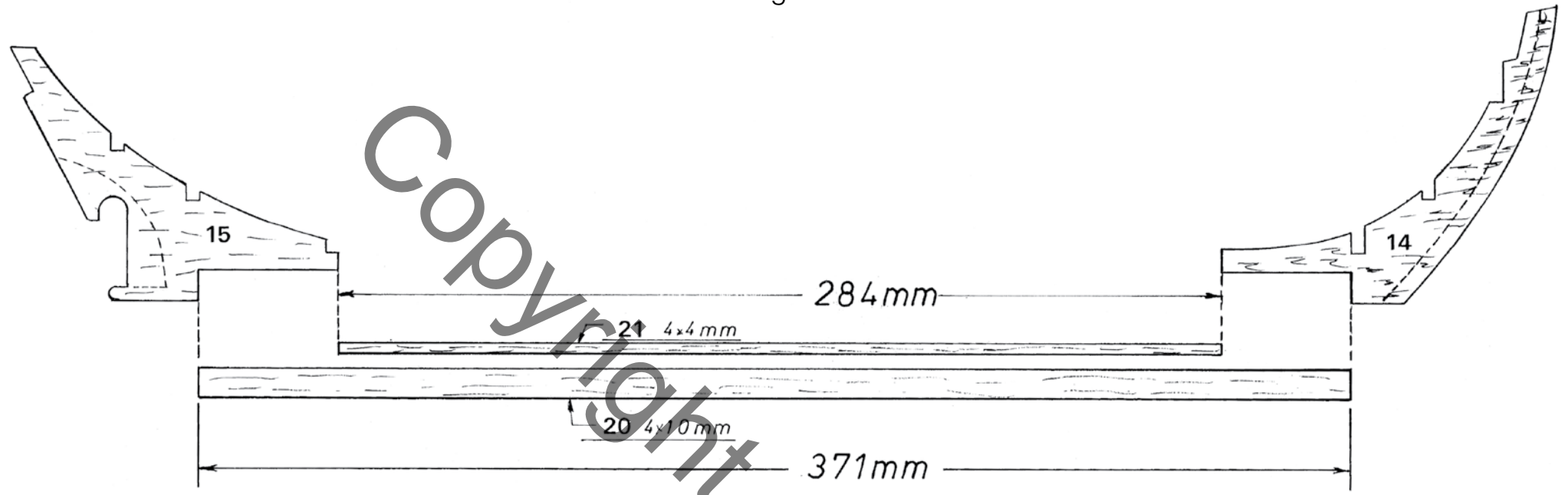

Fig. 2

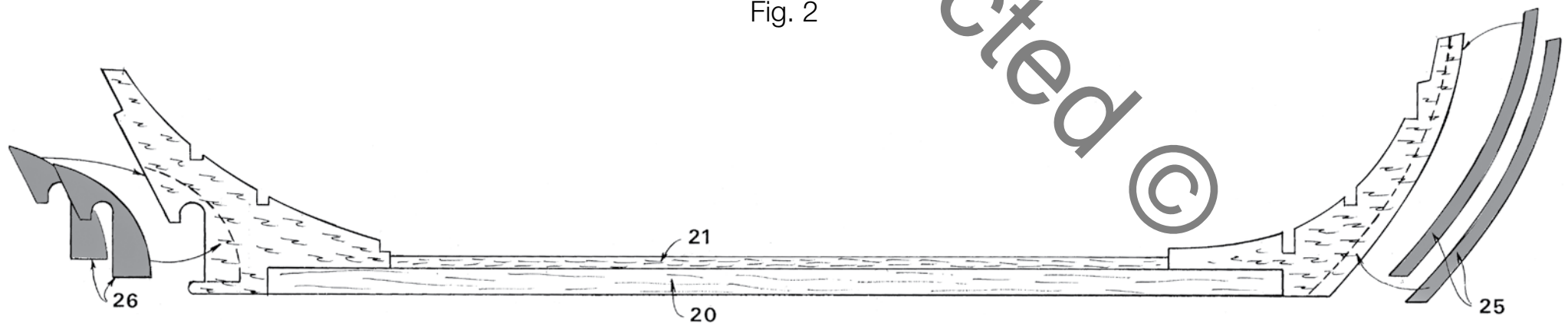

Fig. 3

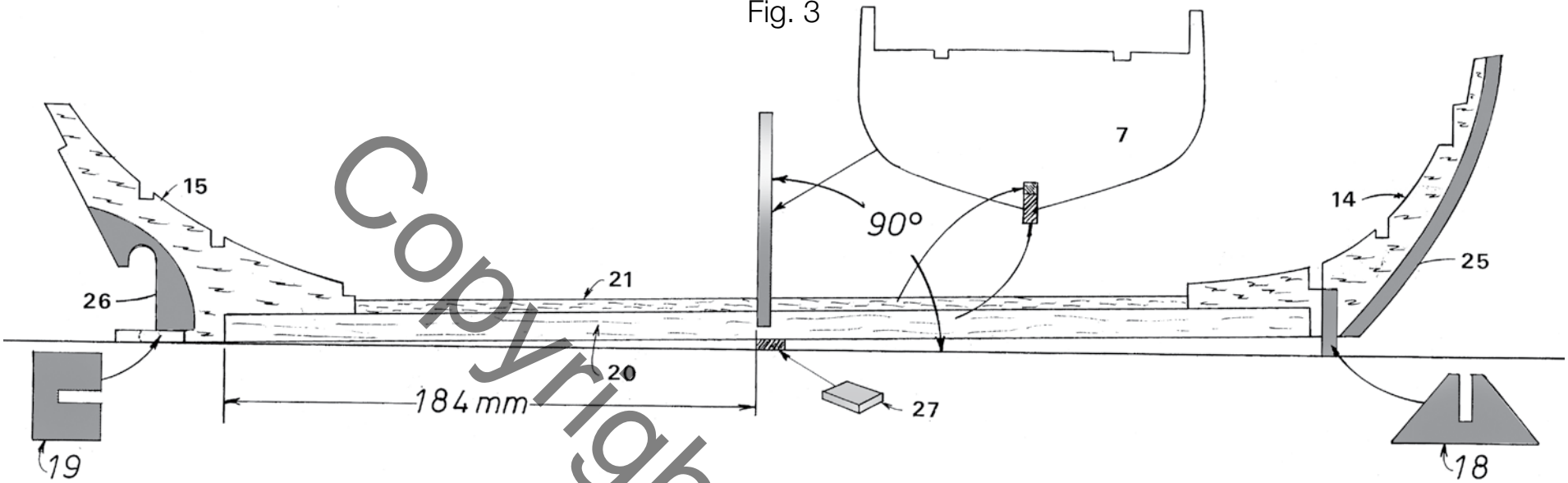

Fig. 4

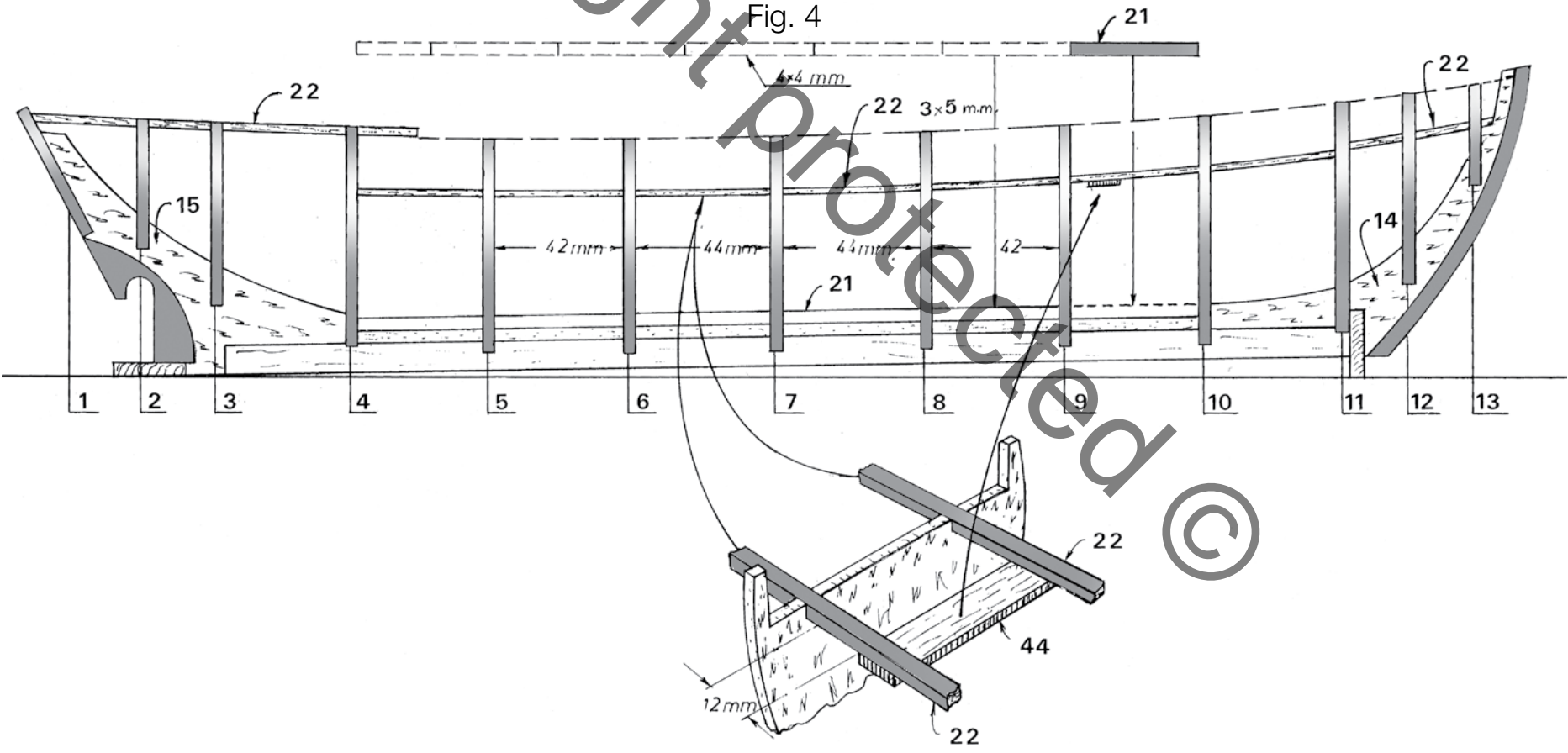

Fig. 5

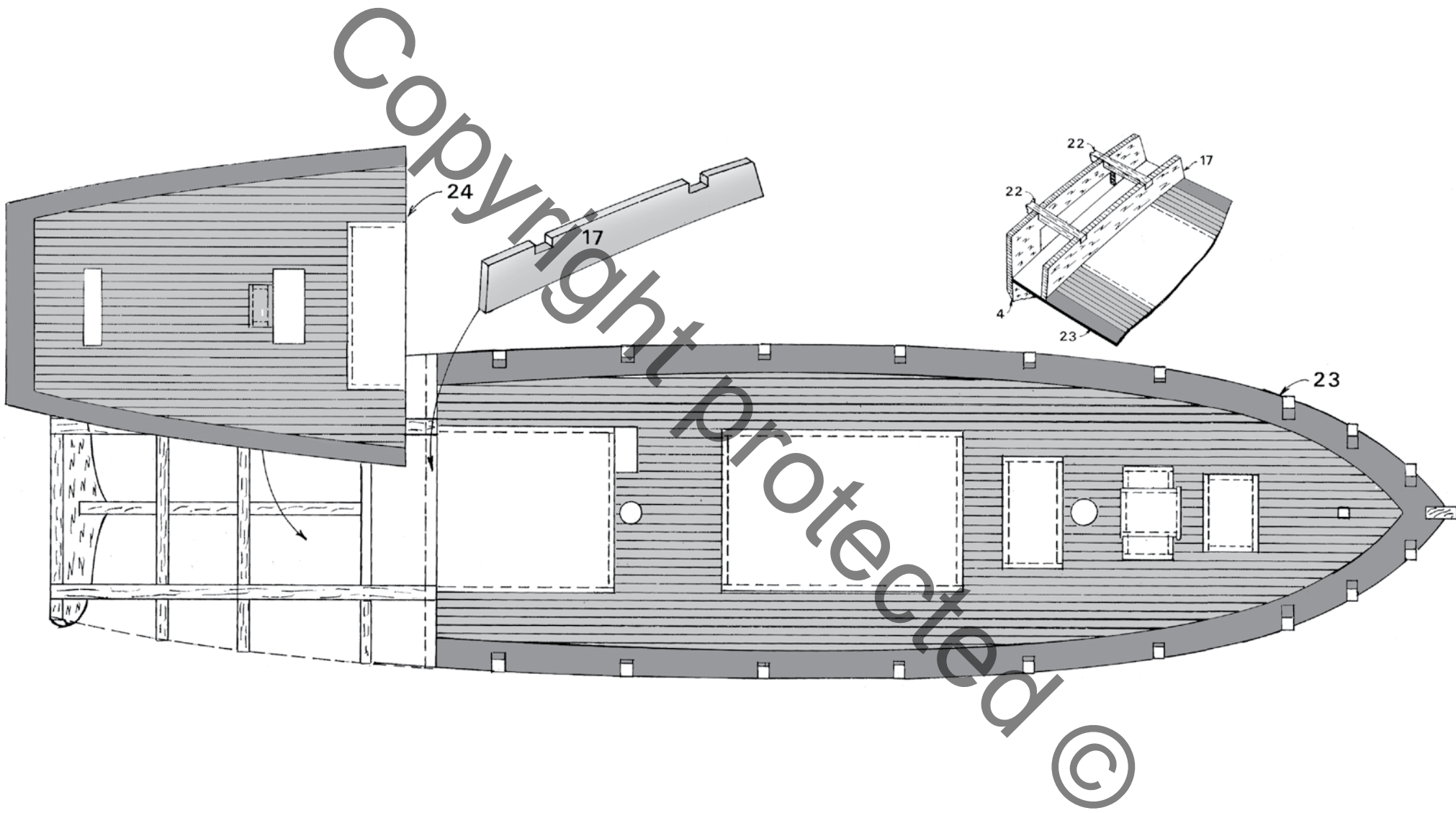

Fig. 6

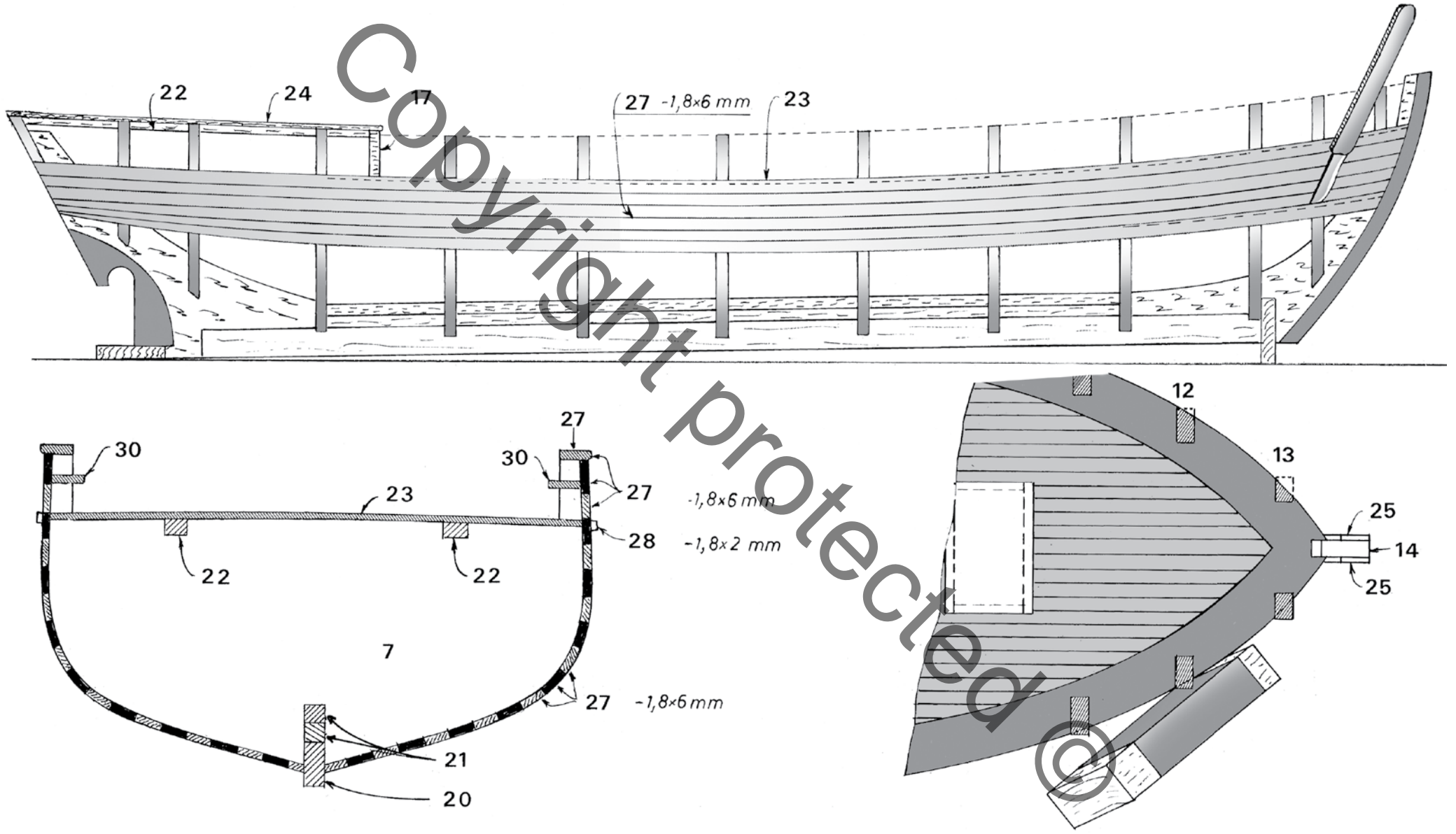

Fig. 7

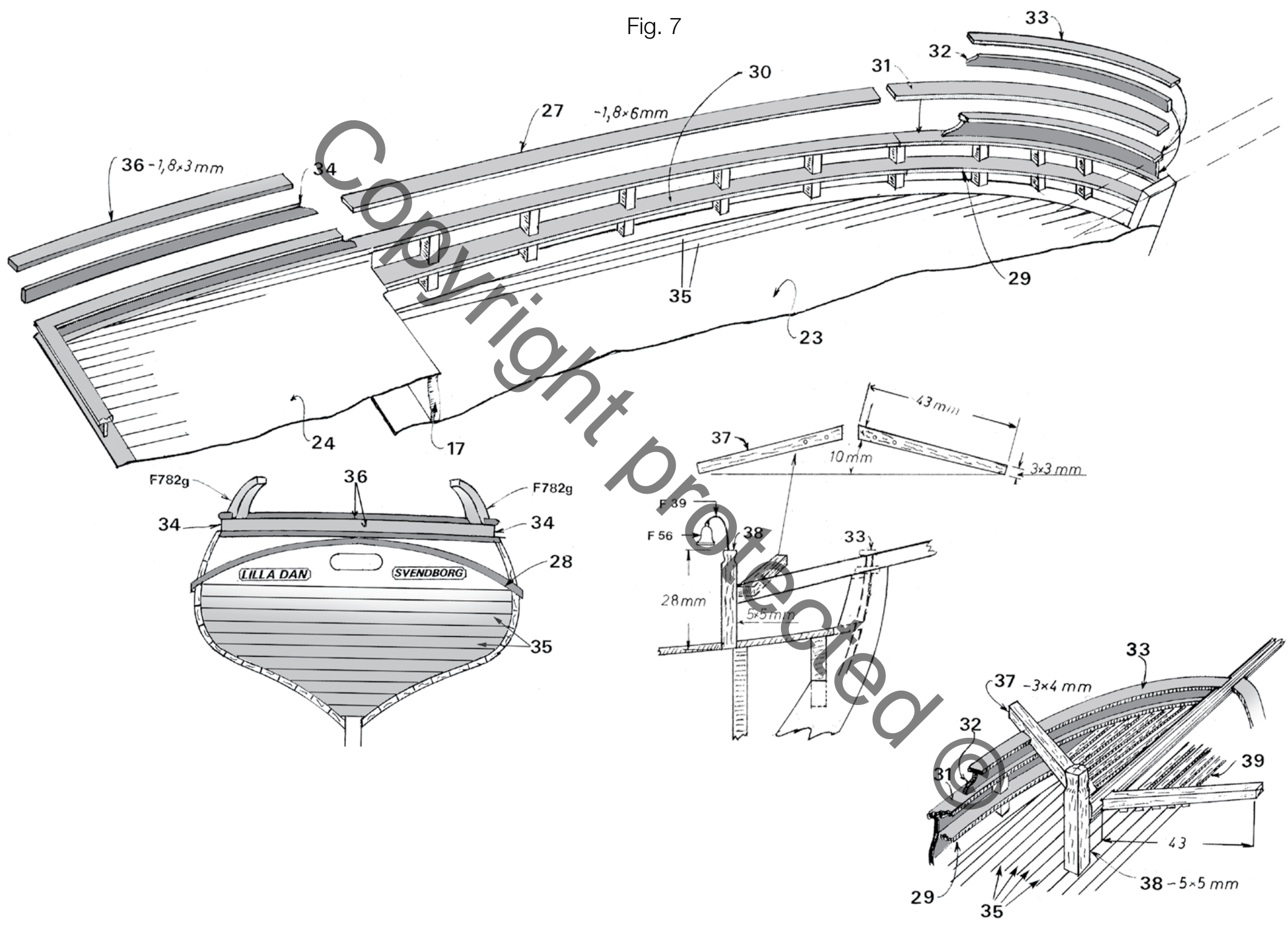

Fig. 8

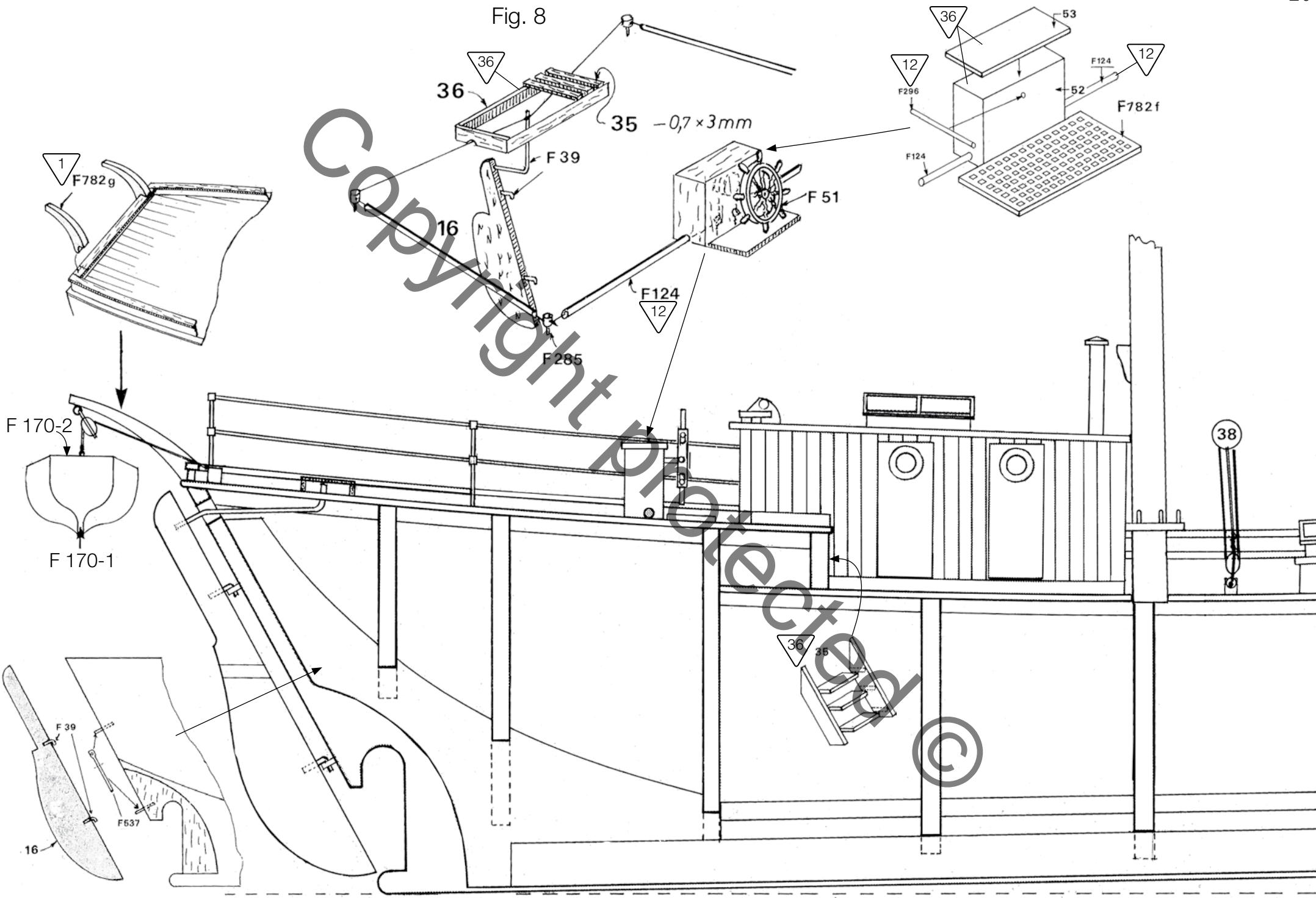
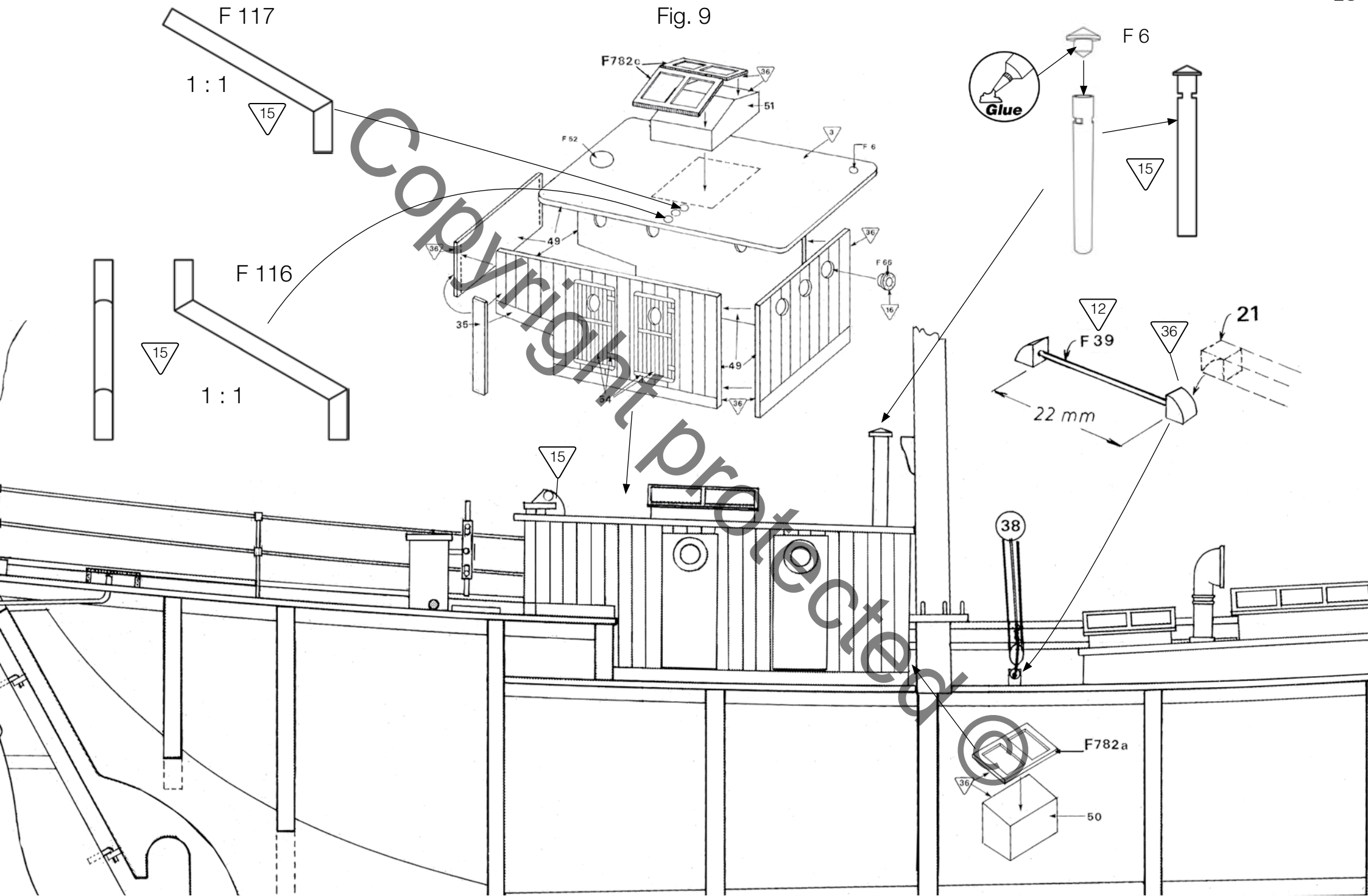

Fig. 9



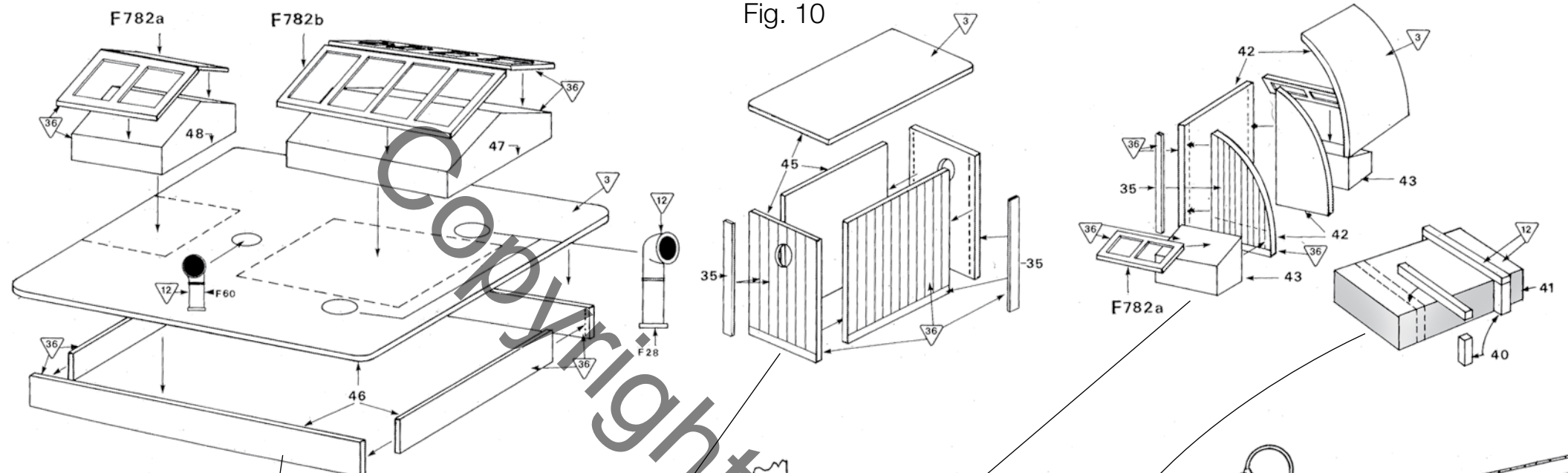

Fig. 10

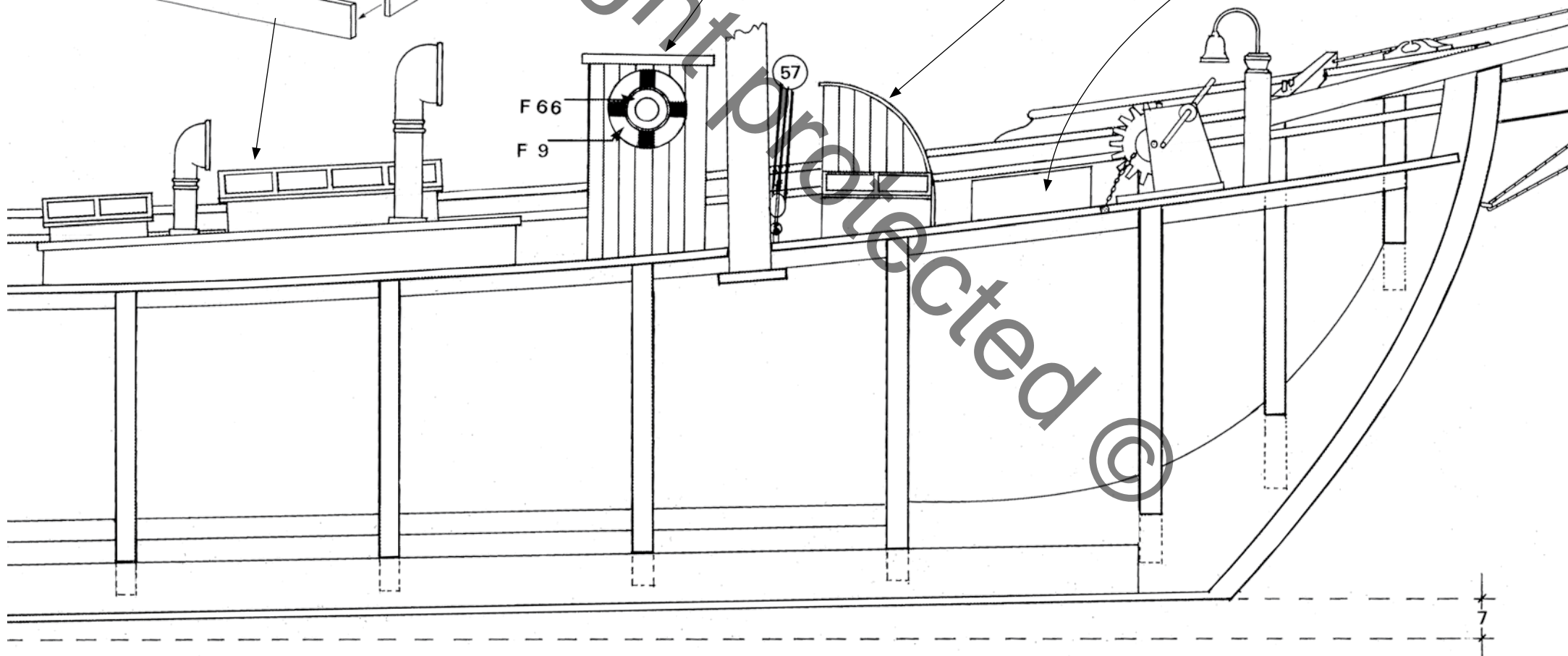
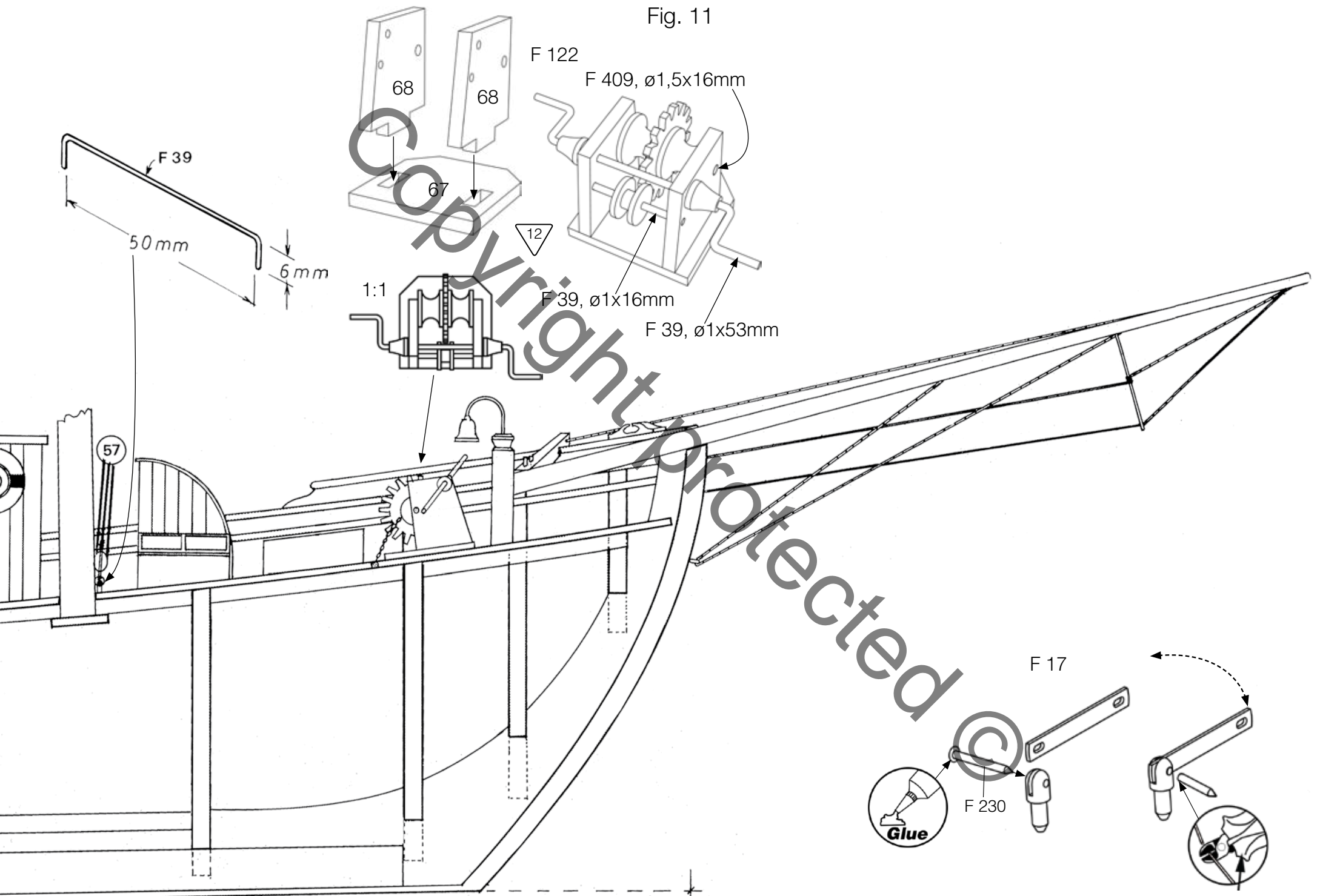
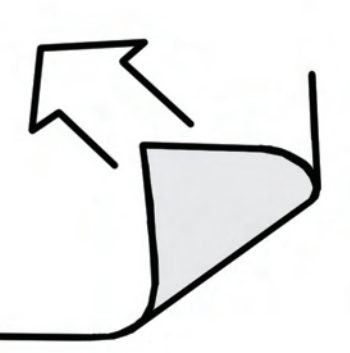
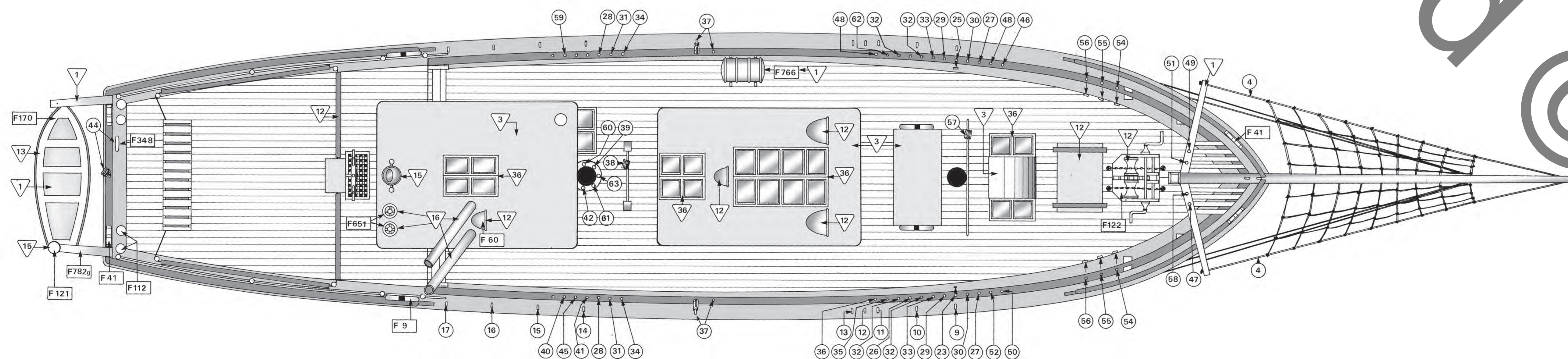
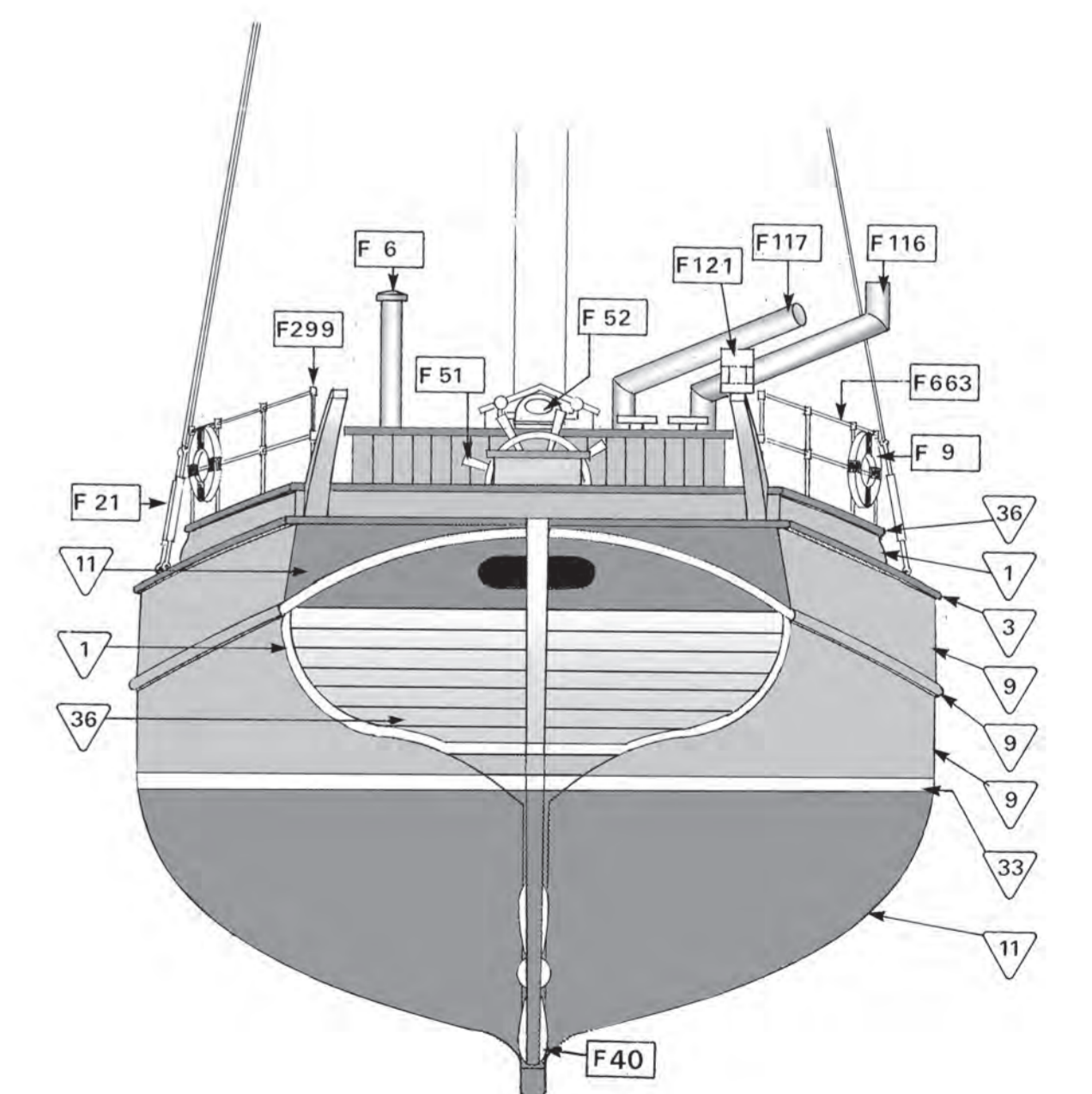
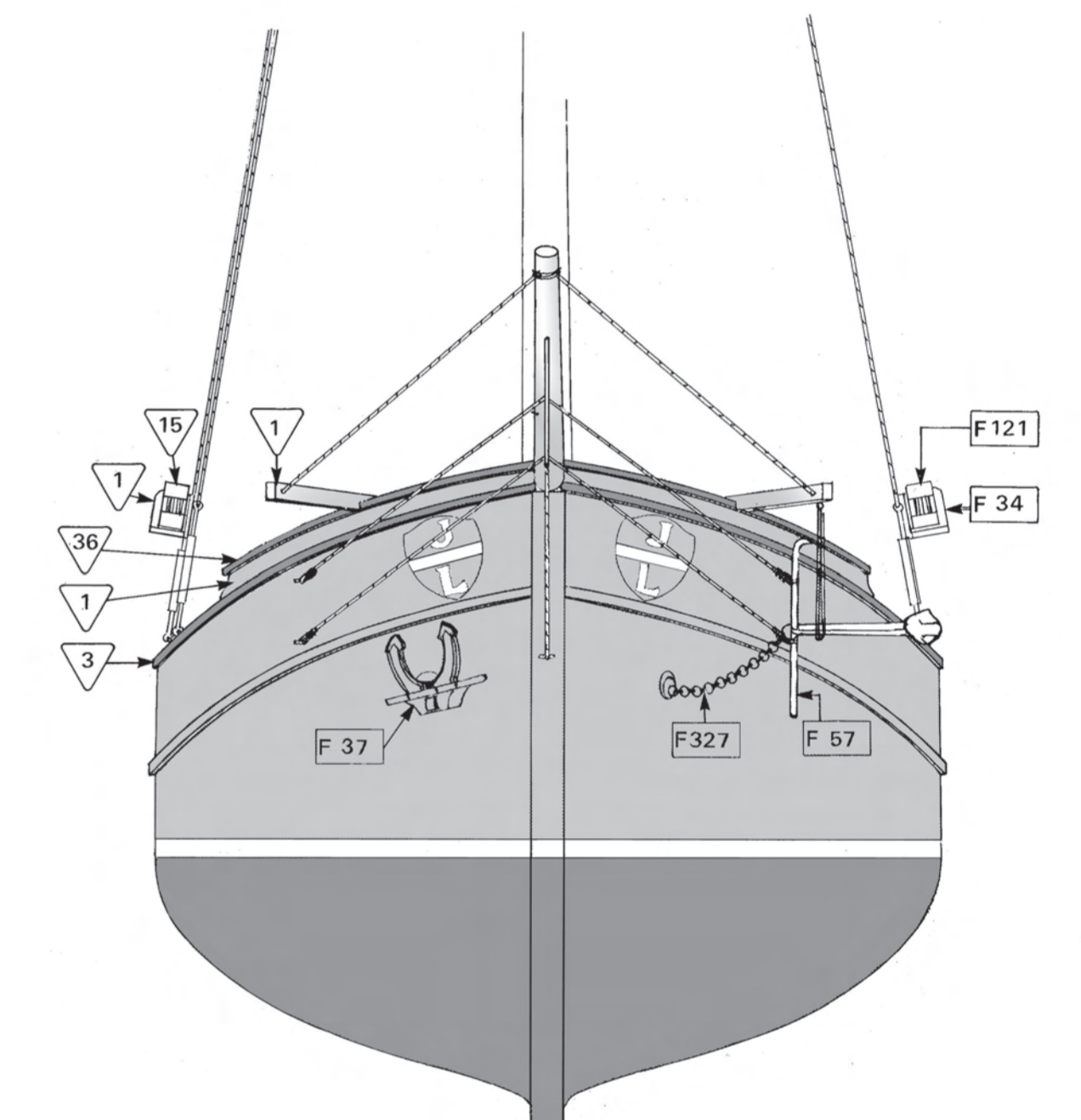
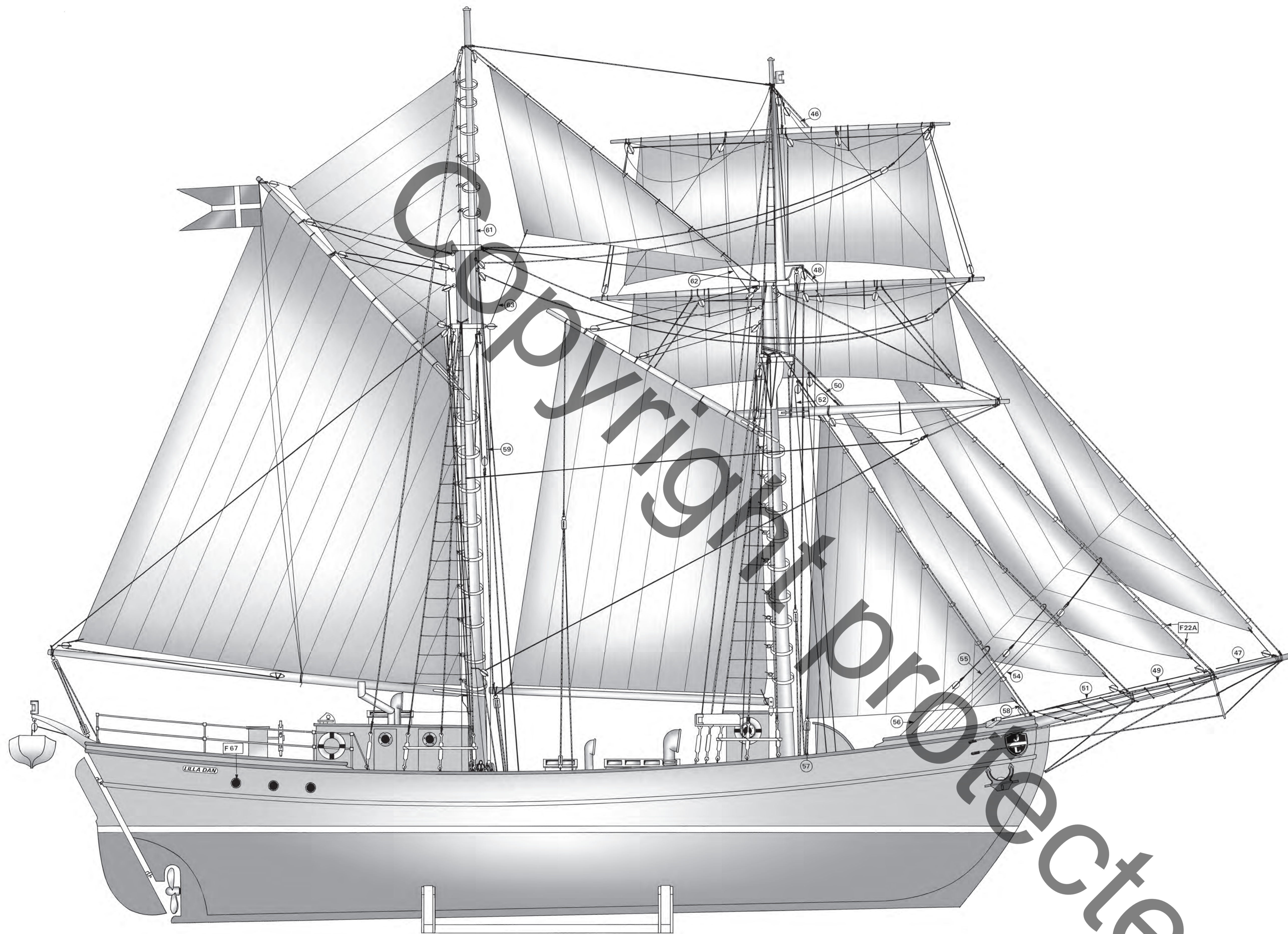

Fig. 11



Drawn by:	K.B.	Billing Boats - Denmark
Date:	09.05.12.	
Scale:	Lilla Dan „578,, Plan 2	Drawing no.
1:50		50-50036



Drawn by:	K.B.	Billing Boats - Denmark
Date:	09.05.12.	
Scale:	1:50	Lilla Dan „578,, Plan 2
		Drawing no. 50-50036

