

Gebrauchsanleitung

DE

Mode D'emploi

FR

Vielen Dank für den Kauf dieser Qualitäts-LED-Lupe.
Bitte lesen Sie diese Anleitung sorgfältig, bevor Sie dieses Produkt verwenden.



BEZEICHNUNG
HERSTELLER NR.
LINSEN

VERGRÖßERUNG
(ARBEITSABSTAND)

LINSENSCHUTZ
LED LICHT
BENÖTIGTE BATTERIEN

LED LUPE
LC1780
5 austauschbare Präzisionslinsen enthalten
mit Vergrößerungen: 1.0x, 1.5x 2.0x, 2.5x, 3.5x

1.0x (250-350mm/10-14"); 1.5x (200-300mm/8-12");
2.0x (175 - 275mm/7-11"); 2.5x (125-250mm/5-10");
3.5x (75-125mm/3-5")

Enthält Linsenbox und Reinigungstuch
LED Spotlicht
3 x AAA 1.5v

ACHTUNG: Bei der Verwendung von Elektroprodukten sind wichtige Sicherheitsvorkehrungen zu beachten, um Brandgefahr, Stromschlag und Verletzungen zu vermeiden.

BITTE LESEN SIE DAS FOLGENDE SORGFÄLTIG:

1. Gebrauch nur in geschlossenen Räumen:

- a. Raumtemperatur zwischen -5 und +40 Grad Celsius
- b. Luftfeuchtigkeit: Höchstens 95%

2. Setzen Sie die Lampe niemals aus:

- a. Hohen Temperaturen
- b. Wasser, Dampf oder Nebelumgebungen
- c. Aggressiven, ätzenden oder brennbaren Flüssigkeiten oder gashaltigen / explosiven Umgebungen
- d. Direkter Sonneneinstrahlung

3 Versuchen Sie niemals, die Kopfbandlupe zu zerlegen oder zu reparieren, es sei denn Sie sind qualifizierter Elektriker.

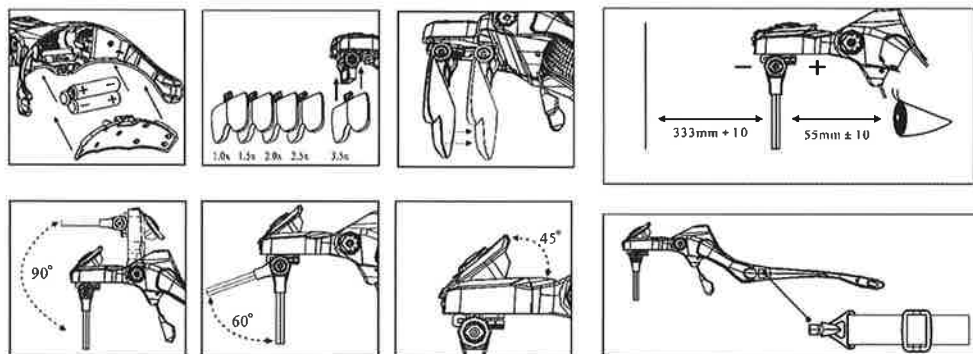

CE Konformitätserklärung

Wir erklären hiermit, dass dieses Produkt CE entspricht.



RoHS Compliant

LightCraft

Shesto, Sunley House, Olds Approach, Watford WD18 9TB
+44 (0) 20 8451 6188 sales@shesto.co.uk
www.shesto.com

Merci d'avoir acheté ce bandeau Loupe à LED.
Veuillez lire ce mode d'emploi avant d'utiliser la lampe.



DESCRIPTION
REF FABRICANT
LOUPES

DISTANCES DE TRAVAIL
/GROSSISSEMENT

PROTECTION DES LENTILLES

LED
BATTERIES
PROTECTION SUPPORT

Loupe à LED
LC1780
Sont incluses 5 Lentilles de précision interchangeables
avec des grossissements de 1.0x, 1.5x, 2.0x, 2.5x, 3.5x
1.0x (250-350mm/10-14"); 1.5x (200-300mm/8-12");
2.0x (175 - 275mm/7-11"); 2.5x (125-250mm/5-10");
3.5x (75-125mm/3-5")
Inclus : boîte de rangement pour lentilles et tissu
de nettoyage
LED blanches
3 x AAA 1.5v
Bouchon en plastique prévu pour cacher la LED
est utilisée indépendamment

ATTENTION: En utilisant un objet électrique, d'importantes mesures de sécurité doivent être suivies pour éviter tous risques de feu, choc électrique et blessure personnelle.

SVP LISEZ CES INSTRUCTIONS AVEC SOIN:

1. Usage intérieur seulement

- a. Température de la pièce de -20 à +40 C°.
- b. Humidité : Inférieure ou égale à 95%

2. Ne pas exposer la lampe à :

- a. Haute température.
- b. Eau, vapeur ou conditions humides.
- c. Liquides corrosifs ou inflammables, ou dans une atmosphère gazeuse/explosive.
- d. à la lumière directe du soleil

3. Ne jamais démonter ou réparer le Bandeau Loupe LED sauf si vous êtes un électricien qualifié

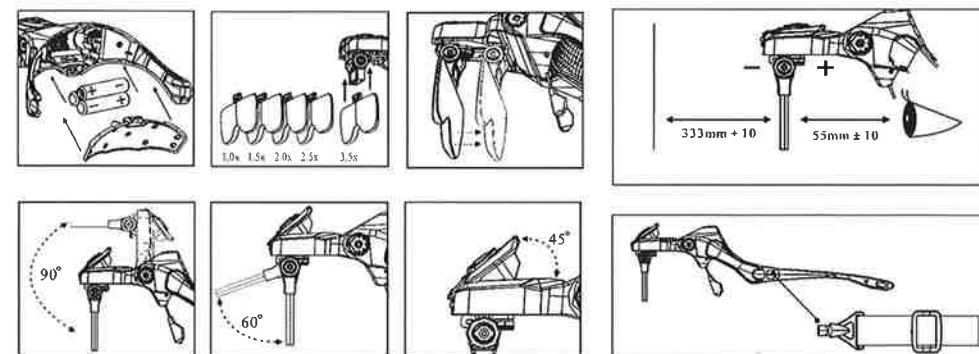

Déclaration de conformité CE

Nous déclarons que ce produit est conforme avec la directive CE



RoHS Compliant

LightCraft

Shesto, Sunley House, Olds Approach, Watford WD18 9TB
+44 (0) 20 8451 6188 sales@shesto.co.uk
www.shesto.com

Gracias por comprar esta lupa de cabeza de alta calidad con luz de LED.
La atentamente estas instrucciones antes de utilizar este producto.



DESCRIPCIÓN
REFERENCIA
LENTES

DISTANCIA DE TRABAJO

PROTECCIÓN DE LENTES
LUZ LED
BATERIAS

Lente de aumento con led para cabeza
LC1780
5 Lentes intercambiables de precisión incluidas
con aumento: 1.0x, 1.5x 2.0x, 2.5x, 3.5x
1.0x (250-350mm/10-14"); 1.5x (200-300mm/8-12");
2.0x (175 - 275mm/7-11"); 2.5x (125-250mm/5-10");
3.5x (75-125mm/3-5")
Incluye caja para lentes y paño de limpieza
LED blanca
3 baterías AAA 1.5v

ADVERTENCIA: Al utilizar productos eléctricos, se deben respetar las precauciones de seguridad para reducir el riesgo de incendio, descarga eléctrica y lesiones personales.

POR FAVOR LEA LO SIGUIENTE CUIDADOSAMENTE

1. Sólo para uso en interior

- a. Temperaturas de -5 a +40 grados centígrados
- b. Humedad menor o igual al 95%

2. No exponga a:

- a. Altas temperaturas
- b. Agua, vapor o humedad.
- c. Agentes corrosivos, líquidos inflamables, o ambientes gaseosos/explosivos
- d. Luz solar directa

3. Nunca intente desmontar o reparar las lentes de cabeza, a menos que sea un electricista cualificado

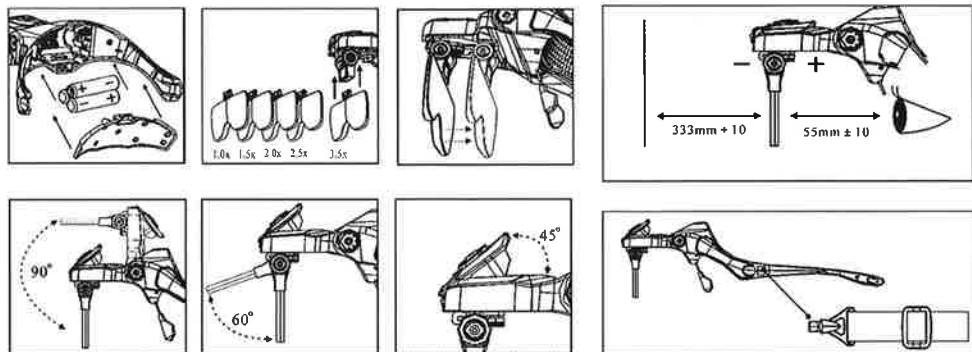

Declaración de conformidad CE

Declaramos que este producto cumple con la normativa CE



RoHS Compliant

LightCraft

Shesto, Sunley House, Olds Approach, Watford WD18 9TB
+44 (0) 20 8451 6188 sales@shesto.co.uk
www.shesto.com

Grazie per aver acquistato questa lampada di qualità a LED.
Si prega di leggere attentamente le istruzioni prima di utilizzare la lampada.



DESCRIZIONE
ARTICOLO
LENTI D'INGRANDIMENTO

MASSIMA DISTANZA

CONFEZIONE LENTI
LUCE LED
BATTERIE

VISIERA CON LENTI A LED
LC1780
5 lenti di precisione intercambiabili:
1.0 - 1.5 - 2.0 - 2.5 - 3.5
1.0x (250-350mm/10-14"); 1.5x (200-300mm/8-12");
2.0x (175 - 275mm/7-11"); 2.5x (125-250mm/5-10");
3.5x (75-125mm/3-5")
Comprende custodia lenti e panno per pulizia
Riflettore a LED
3 x AAA 1.5v

ATTENZIONE: Quando si usano prodotti elettrici sono molto importanti le misure di sicurezza che devono essere rispettate al fine di ridurre il rischio di incendi, scosse elettriche e lesioni personali.

PER FAVORE, LEGGERE ATTENTAMENTE QUANTO SEGUE:

1. Solo uso in ambiente interno:

- a. Temperatura ambiente da -5 a +40 gradi centigradi
- b. Umidità: Meno o uguale al 95%

2. Non esporre la lampadina a:

- a. Alte temperature
- b. Acqua, vapore condizioni di umidità
- c. Liquidi infiammabili, ambienti corrosivi o atmosfere esplosive/ gassose
- d. Luce diretta

3. Non tentare di smontare o riparare la lampada, assistenza presso elettricista qualificato

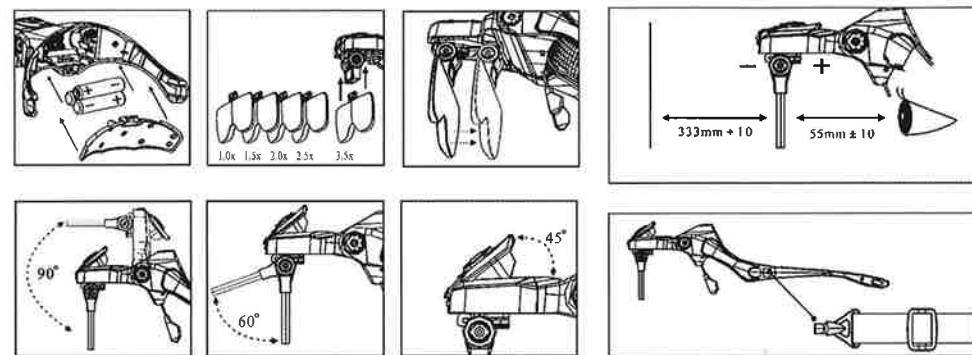

Dichiarazione di conformità CE

Dichiaro che questo prodotto è conforme alle normative CE



RoHS Compliant

LightCraft

Shesto, Sunley House, Olds Approach, Watford WD18 9TB
+44 (0) 20 8451 6188 sales@shesto.co.uk
www.shesto.com

Instruction Leaflet

GB

Thank you for purchasing this quality LED Magnifier.
Please read these instructions carefully before using this product.



DESCRIPTION
MANUFACTURER REF.s
VOLTAGES AVAILABLE
MAGNIFIER
MAGNIFICATION

LENS PROTECTION
LED LIGHT SPECIFICATION
BATTERIES

LED MAGNIFIER
LC1780
220v & 240v, 50Hz
5 Precision interchangeable lenses included
1.0x (250-350mm/10-14"); 1.5x (200-300mm/8-12");
2.0x (175 - 275mm/7-11"); 2.5x (125-250mm/5-10");
3.5x (75-125mm/3-5")
Includes lens case & cloth
LED white spotlight
3 x AAA 1.5v

WARNING: When using electrical products, important safety precautions must be adhered to in order to reduce the risk of fire, electric shock and personal injury.

PLEASE READ THE FOLLOWING CAREFULLY:

1. Indoor use only:
 - a. Room temperature from -5 to +40 degrees centigrade
 - b. Humidity: Less than or equal to 95%
2. Do not expose the lamp to:
 - a. High temperatures
 - b. Water, steam or damp conditions
 - c. Corrosive, flammable liquids, or gaseous / explosive atmospheres
 - d. Direct sunlight
3. Never attempt to disassemble or repair the Headband Magnifiers, unless you are a qualified electrician

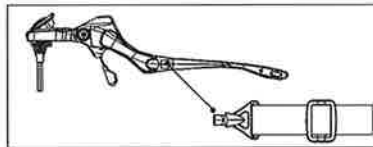
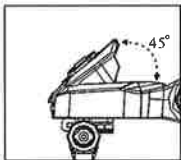
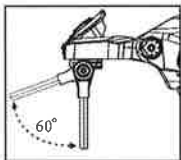
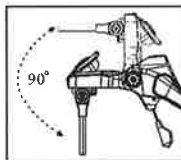
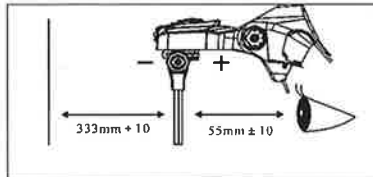
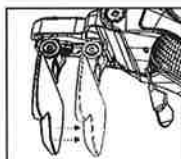
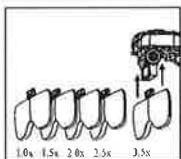
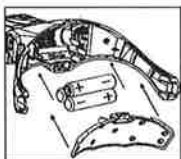

CE Declaration of Conformity

We declare that this product complies with CE



RoHS Compliant

LightCraft

Shesto, Sunley House, Olds Approach, Watford WD18 9TB
+44 (0) 20 8451 6188 sales@shesto.co.uk
www.shesto.com