

# MINI AIR COMPRESSOR AC-27 (ia)

## PART LIST

UL file No.E227093

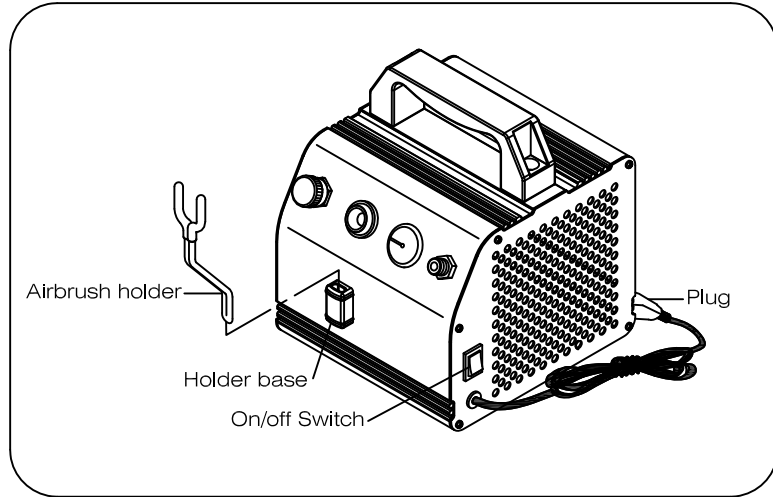

**NOTE :** When working with adjusted air pressure,airflow will constantly leak from the Pressure adjustment knob thus rendering the automatic shut off feature inoperative.  
Closing the Pressure adjustment knob will reinstate the auto shut off feature.

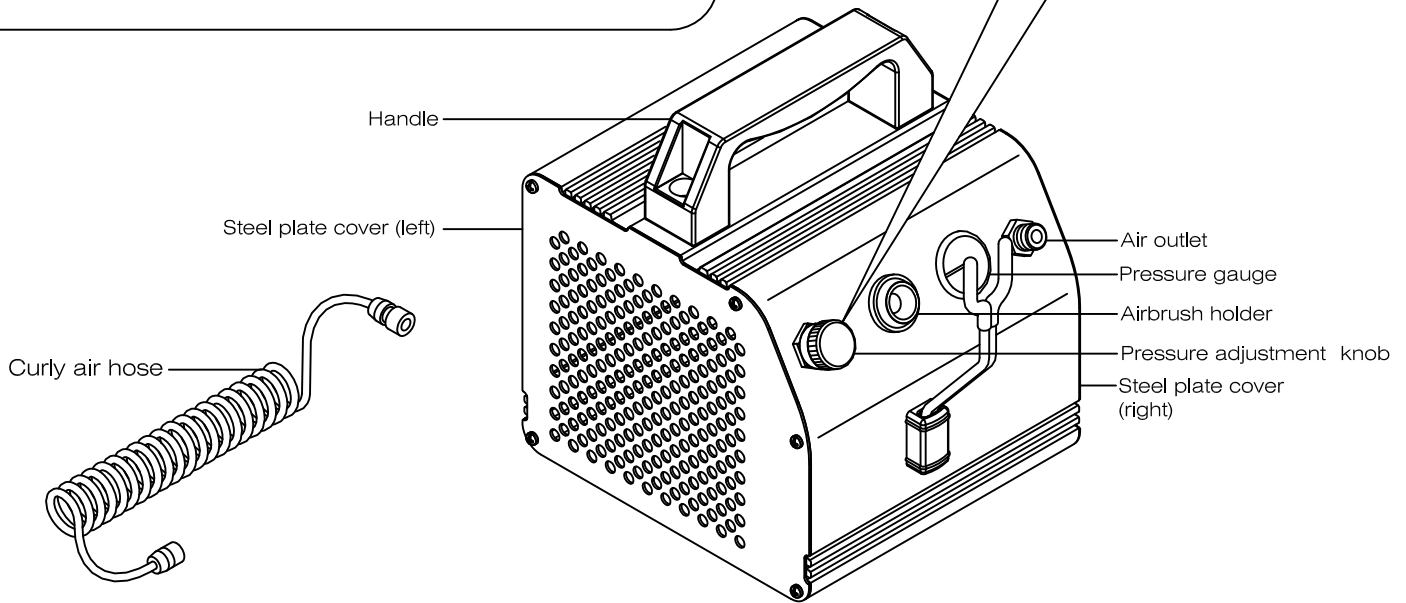

※Please check the Voltage/Spec. label on the machine

### APPLICATION PRECAUTION

- 1) Carefully unpack the machine and check if any part is damaged during transportation. Any damage should be reported immediately to the service agent.
- 2) Plug the compressor into mains supply, making sure the voltage is correct. Screw one side of the air hose onto the compressor outlet and connect the other end to the airbrush. To make sure all connections are tightened, it is also recommended to use Plumbers Teflon Tape on all threaded connections. (Extra fittings may be required for various airbrush brands, models, please check with the distributors for supply.)
- 3) Turn on the machine and work in a well ventilated, clean area and away from wet surfaces.
- 4) The compressor has a thermal switch that automatically shuts off itself when it becomes overheated or lacks voltage. Additionally, this model is equipped with an auto stop pressure switch. When the trigger of the airbrush is released, the compressor will stop automatically.
- 5) Adjust the pressure by turning the *Pressure Adjustment Knob* clockwise for more pressure. Turn counter-clockwise for less pressure. Adjust pressure only when the compressor is turned on and connected to the airbrush.
- 6) Do not touch the air compressor during or soon after use as it may become hot.
- 7) Do not use any lubricants, or spray flammable, toxic materials as they may damage the air compressor.
- 8) When restarting the compressor during operation, always release the compressed air from the airbrush first and then turn on again.
- 9) In case the auto stop pressure switch malfunctions, do not allow the motor to operate over 50 psi.
- 10) After finishing with the compressor, turn the switch to off position and depress the airbrush trigger to fully release the remaining air from the compressor.
- 11) Improper operation and dismantling of the parts might damage the compressor. If any parts of the machine are damaged, it must be sent to the service agent for replacement or repair to avoid hazard. Do not attempt to fix the machine without consulting the service agent first.